



## PLOUGHING

Mounted Ploughs | Semi-Mounted Ploughs | Packer



The entire range at a glance.

# TABLE OF CONTENT.

<b>Table of Content</b> .....	02
<b>RABE – A strong Brand</b> .....	04
<b>Mounted in-furrow Rollover Ploughs</b>	
<b>ALBATROS   SUPER ALBATROS</b> .....	06
Features and Highlights .....	08
Frame and Headstock .....	10
Pull Point Adjustment and Re-Alignment Cylinder .....	12
Front Furrow Adjustment .....	14
Working width – fixed or Variant .....	16
Shear Bolt Overload Protection .....	18
Non-Stop Overload Protection .....	20
Packer Arms .....	22
<b>CONDOR</b> .....	24
Frame design and First Furrow Adjustment .....	26
Wheels for Mounted Rollover Ploughs .....	28
Technical Data Mounted Ploughs .....	30
<b>Semi Mounted Rollover ploughs</b>	
<b>KORMORAN</b> .....	32
Two Models: KORMORAN SF and PF / PL .....	34
Features and Highlights .....	36
Headstock .....	38
Frame .....	40
Working width – fixed or Variant .....	42
Wheels .....	44
<b>MARABU</b> .....	46
Features and Highlights .....	48
Frame .....	50
Wheels .....	52
Accessories for KORMORAN and MARABU .....	53
Technical Data Semi Mounted Ploughs .....	54
<b>For all RABE Ploughs</b>	
Mouldboards .....	56
Skimmer and Trashboards .....	58
RABE Options .....	60
<b>Packer</b> .....	62
<b>RABE Product Portfolio</b> .....	64
<b>RABE Service</b> .....	65
<b>RABE Genuine Parts</b> .....	66

# DISTINGUISHED PLOUGHING SOLUTIONS FOR YOUR INDIVIDUAL NEEDS.

## Covering more hectares in the most efficient way.

Covering more hectares in a given time frame with superior productivity, maximum uptime and the lowest cost of operation today is key to ensure sustainable farm profitability in any application throughout the year. To meet the individual needs for primary tillage applications of our most demanding customers better than ever before, RABE offers a wide range of different plough models and configurations to make life easier, more productive and more efficient in the field.

### ALBATROS

The ALBATROS plough range delivers superior ploughing performance in a light-weight and compact package. It's the ideal choice for:

- » Small to medium size farms
  - » Lighter conditions
  - » Smaller tractors with limited lift capacities
- » See more on page 6



### SUPER ALBATROS

The SUPER ALBATROS plough range combines maximum strength, superior rigidity, highest versatility, utmost compactness and high performance in a 3-point mounted package. It's the right choice for:

- » Medium size mixed and livestock farmers as well as larger arable farms
  - » Rough conditions
  - » Customers who do not want to make compromises on overall weight
- » See more on page 6



### CONDOR

The CONDOR has been specifically designed for customer who require a highly productive plough for high horsepower tractors with wide tyres:

- » Still need a mounted plough for smaller and irregularly shaped fields
  - » Want to plough on-land
- » See more on page 24



### KORMORAN

KORMORAN in-furrow and on-land semi mounted rollover ploughs address our most demanding customers when it comes to cover as many hectares as possible in a given and short ploughing window. It's the right choice for customers:

- » Who are looking for a highly productive single wheel semi-mounted plough
  - » Want a purpose build solution that lasts
- » See more on page 32



### MARABU

With the MARABU RABE defines machine performance as much more than just power. The MARABU semi-mounted rollover plough is ready to go in the field when the timing is there:

- » Peerless productivity
  - » Maximum uptime
  - » Minimum cost of operation
  - » Meet the critical ploughing window extra-large arable farms typically have to deal with
- » See more on page 46



VISION CREATES FUTURE

# RABE – A STRONG BRAND.

## Committed and focused on today's and tomorrow's customers.

"Vision creates Future" – our pedigree of more than 130 years of experience in developing and manufacturing highly innovative technologies for tillage and seeding operations in Bad Essen provides the foundation for a successful partnership with our most demanding customers today and tomorrow. It's our relentless goal to deliver the most modern solutions to make your business more profitable than ever before in any step of your tillage, seeding and fertilizing operations.

"Vision creates Future" is our motivation driver in any step of the delivery process, starting with the design, innovation and robustness of the products, the quality of production, the expertise in sales and service, the parts delivery and finally ending up at the overall commitment of our employees. A solid education and an ongoing training is therefore key.

And as a subsidiary of the ZOOMLION Group, RABE can count back on the experience and knowledge of a worldwide operating partner and leverage solution and technologies used on multiple product platforms throughout the world.



### + Most modern product development

State-of-the art development programs and computer aided design analysis support a fast overall design process, eliminate potential risks in the design before the first prototype has been build and therefore accelerate the entire process from testing a first prototype until releasing the product.

### + Comprehensive testing

All RABE developments undergo a stringent testing process that includes long term lab tests, testing at the factory and on-site field testing at selected customers to embrace all types of valuable input at a very early stage of the development.

### + Patented technologies

Patented technologies such as RABE CONIT and RABEDUR ensure most wear resistant parts produced, hardened and tempered in house in our own forge.

### + Precision work

Cutting sophisticated parts is done with a plasma gun faster and more accurate than anything else to make sure individual components fit together free of play for long life performance.

### + Most accurate robot welding

Special welding is done fully automatically by robots to deliver a consistent welding quality throughout the entire product range and completely independent from daily up and downturns.

### + State-of-the-art painting

A new paint facility seamlessly integrated into a continuous production flow guarantees a perfect paint finish. The 5 step process of washing, scouring, preheating, priming and coating tops off the quality of our products.

### + Investing into future employees

A comprehensive education and ongoing training is key at RABE. Delivering skills from one generation of employees to the next differentiates us from others and makes us better together.





### + Sharing information and know how

A continuous engagement between research and development, production, sales, customer support and quality management in Germany and China within the ZOOMLION Group provides the foundation to deliver highly productive and durable products and solutions that exactly match the needs of our most critical customers. Furthermore it proves the ongoing commitment of leveraging cost efficient synergies within the group in terms of line production of critical components to finally deliver products that last.



**ALBATROS | SUPER ALBATROS**

# **MOUNTED IN-FURROW ROLLOVER PLOUGHS – STRIKING PERFORMANCE IN A COMPACT DESIGN.**

## **ALBATROS Range**

The ALBATROS plough range is made from high resistant steel quality. In combination with integrated frame bushings it ensures maximum rigidity in a lightweight package to exactly match medium size tractors.

- + Tractor horsepower ranges from 80 – 200 hp**
- + 110 or 120mm robust square tube frame design**
- + Up to 6 furrows (depending on the model)**
- + Various options such as variable width of cut adjustment and non-stop overload protection**



## **SUPER ALBATROS Range**

The Super ALBATROS range takes productivity to the next level and precisely addresses the high horsepower tractor segment without compromising on lightweight and superior rigidity. It's the ideal choice to deal with high residue fields.

- + Tractor horsepower ranges up to 300 hp**
- + 140 or 160mm robust square tube frame design**
- + 90, 100 or 120cm point to point distances**
- + Under beam clearance of 80 cm**

Both ranges, ALBATROS and SUPER ALBATROS, feature a base frame that is capable to add another pair of bodies in the rear. It allows customers to tailor their plough exactly to existing tractors but keep the opportunity to grow with a new tractor even after years of operation.





# ALBATROS | SUPER ALBATROS

## FEATURES AND HIGHLIGHTS.

### Suspended Headstock

Smooth handling in the field and on the road. Less stress applied to plough and tractor.

» Details see page 10/11

### Hydraulic first furrow adjustment

Fast adjustment and fine tuning in the field through slider. Compact design. Always optimum pull point.

» Details see page 15

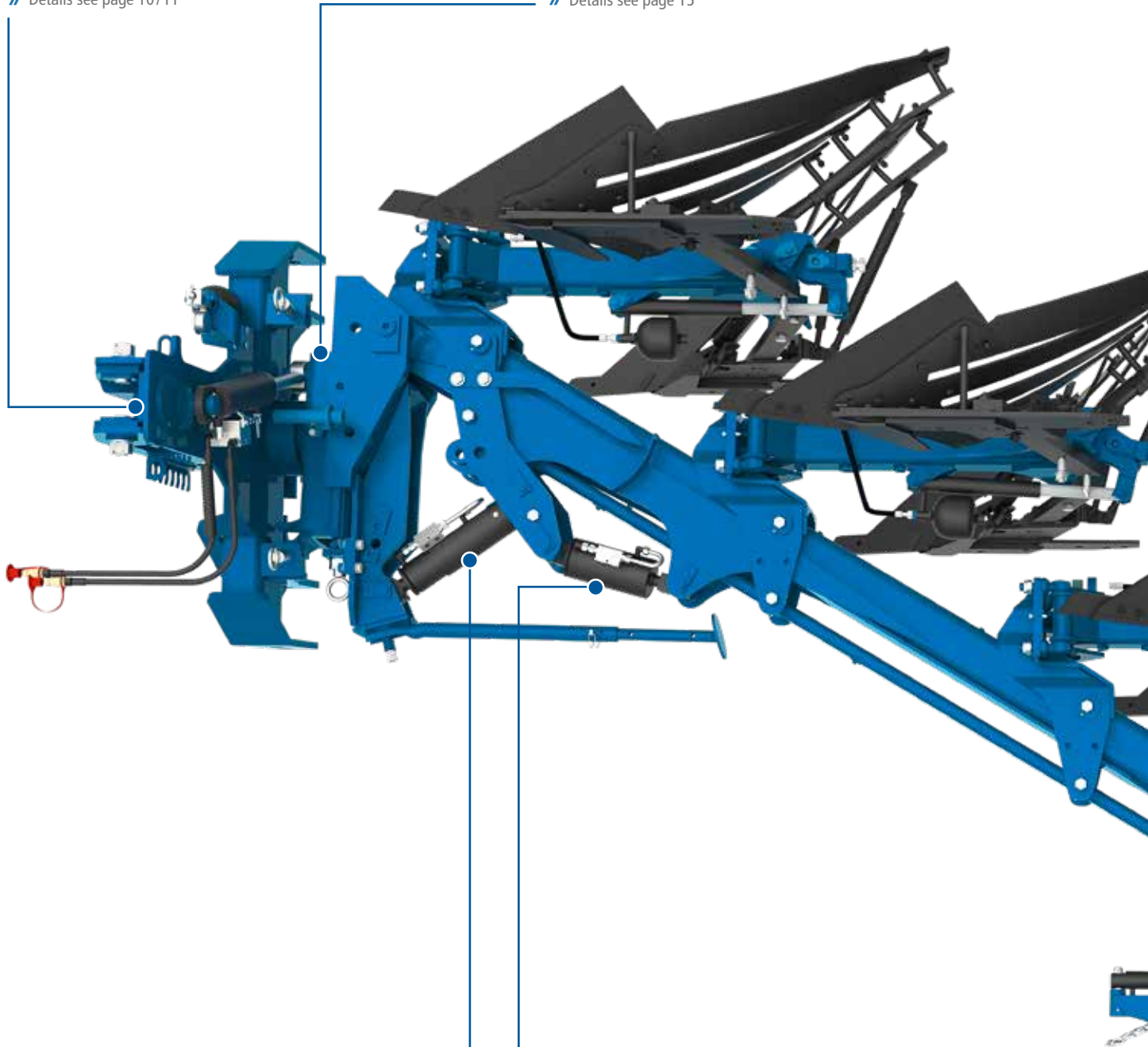

### Hydraulic realignment

Optimum center of gravity for more stability and higher ground clearance during rollover.

» Details see page 13

### Hydraulic adjustment of cutting width

Infinitely variable width of cut adjustment on-the-go. Optimum capacity utilization of the tractor and perfect soil crumbling in any condition.

» Details see page 16



## HYDRO AVANT Non-Stop protection

Tripping vertically and horizontally to avoid serious damage. High trip force and maximum downforce in working position for superior pulling behavior and low fuel consumption.

» Details see page 20/21

## Consoles and Pre-stressed Body-Fit Bolts

High contact pressure and play free connection for more strength and low maintenance cost.

» Details see page 16/17

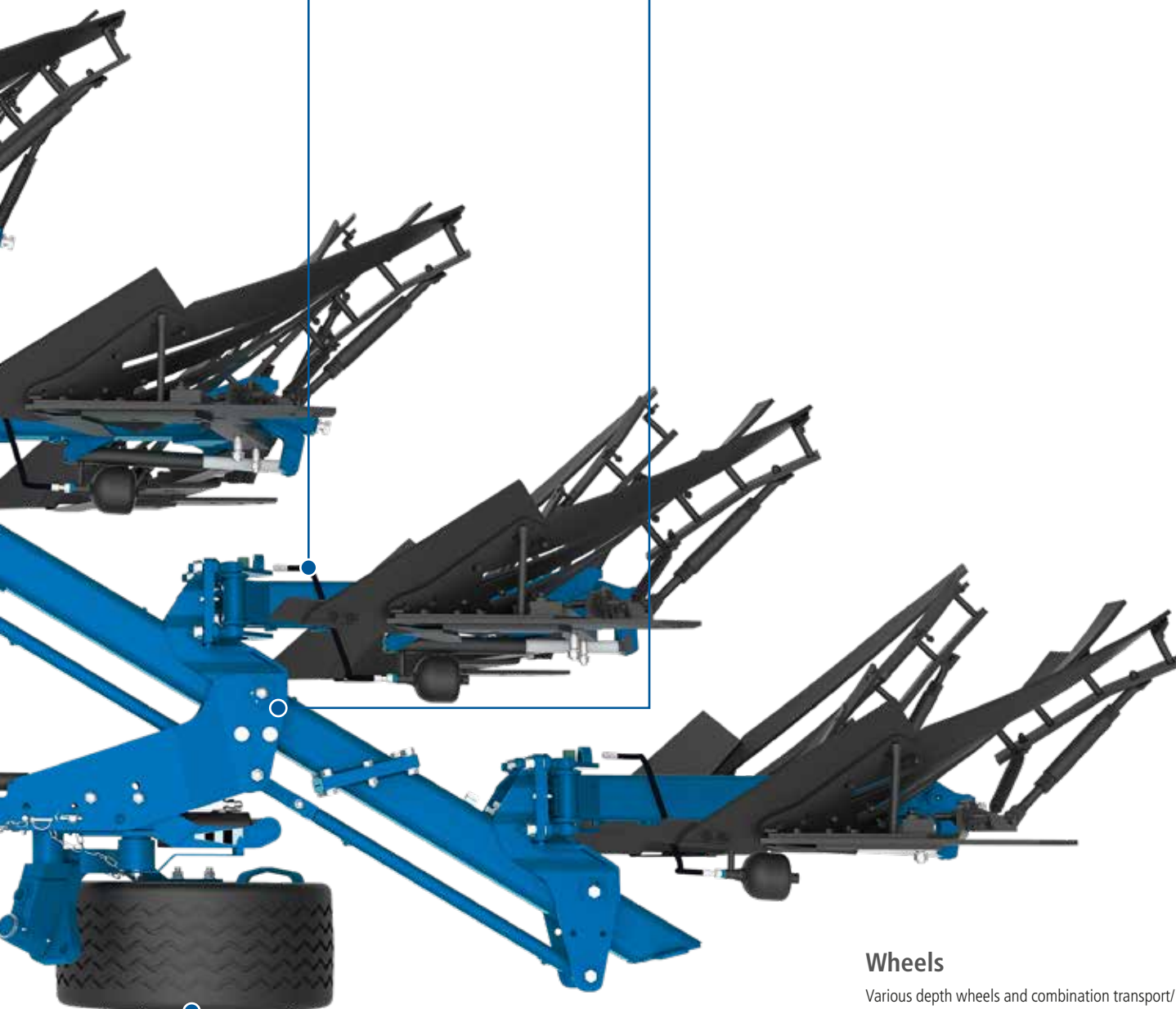

## Wheels

Various depth wheels and combination transport/depth wheels for most accurate depth control.

» Details see page 28/29

# FRAME AND HEADSTOCK – SOLUTIONS THAT MAKE A SIGNIFICANT DIFFERENCE.

## Different designs tailored for different demands.

Both headstocks share a robust construction. While the new SUPER ALBATROS headstock is designed for powerful tractors up to 300 hp the design of the ALBATROS headstock has to consider the limited lifting forces of small and medium tractors.

Both headstocks mount tight behind the tractor to keep the first furrow close to the rear axle for narrow headlands. Furthermore the shorter plough minimizes weight transfer for improved lifting and better overall handling.

The headstock of the SUPER ALBATROS is optionally available with a headstock suspension. It delivers the following customer value:

- + Absorbs shocks transferred to the headstock, rollover mechanism and frame
- + Minimize serious stress on plough and tractor on the road and in the field
- + Fully integrated into the design of the headstock
- + Does not increase the overall length of the plough

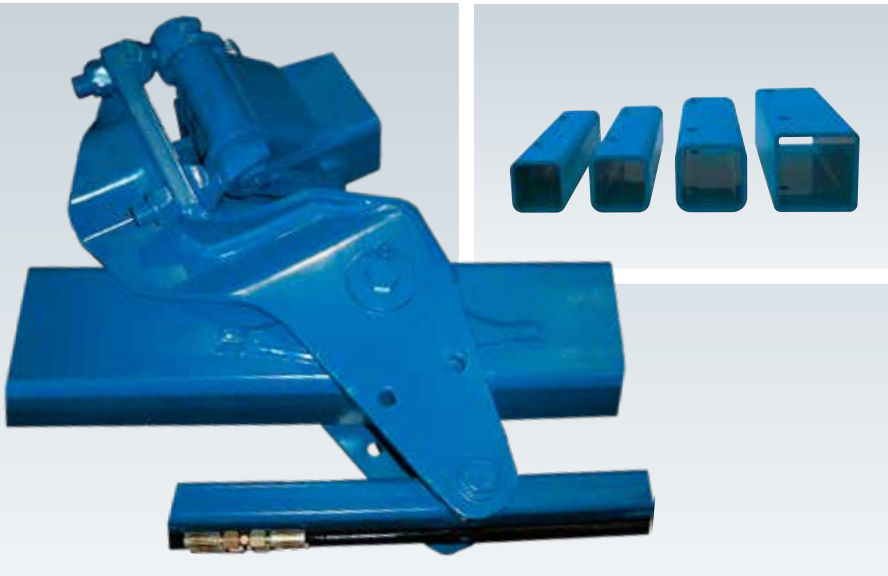

### Frame Design

All RABE ALBATROS and SUPER ALBATROS ploughs feature a heat treated and straightened frame made from high tensile, high quality steel material. A square tube with 8 mm wall thickness (ALBATROS 110) respectively 10 mm (ALBATROS 120 and SUPER ALBATROS) provides the required robustness and stiffness to withstand the toughest field conditions and soils.



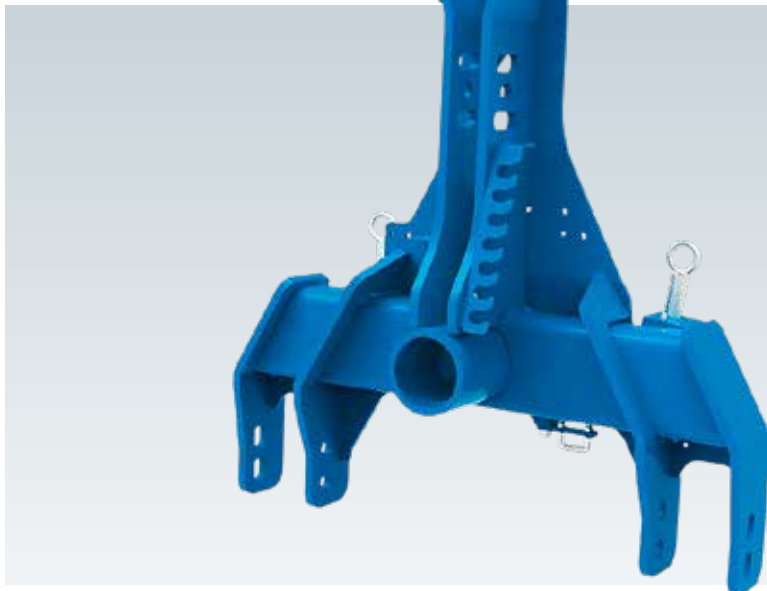
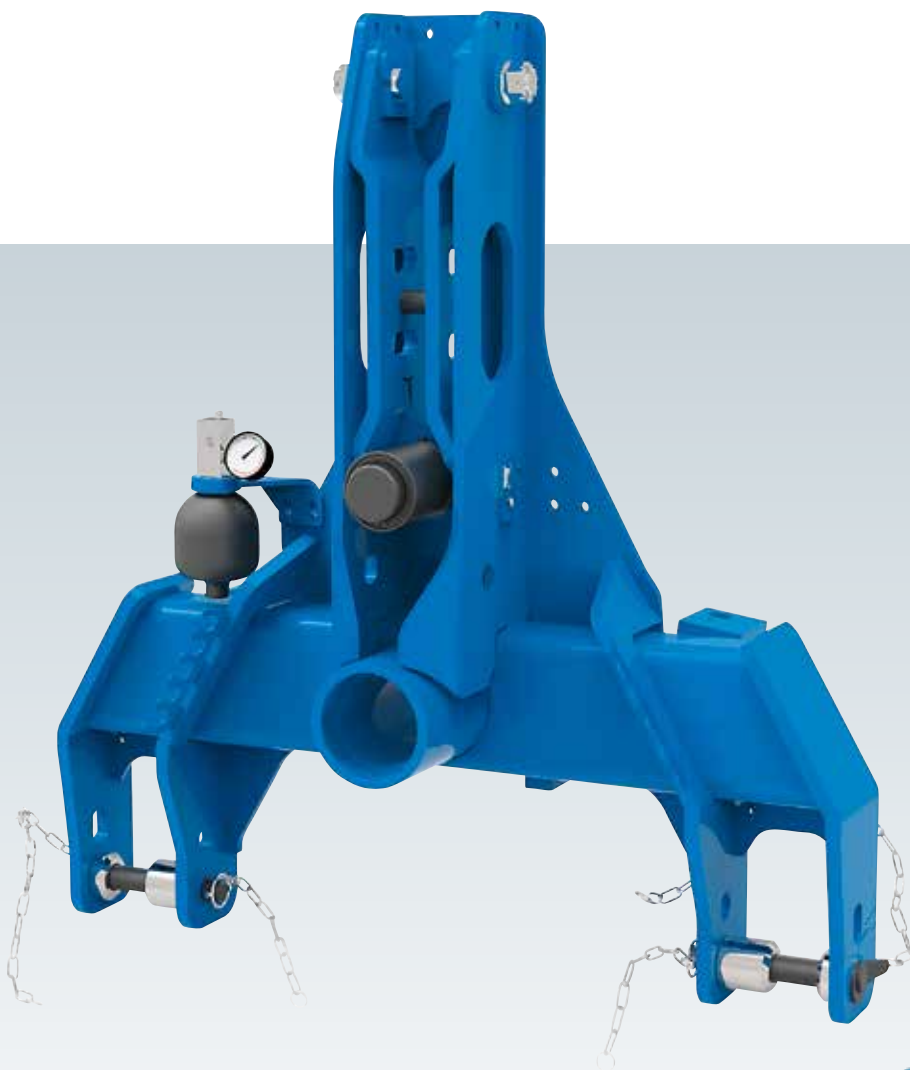

### Rigid Headstock ALBATROS and SUPER ALBATROS

The headstock of the ALBATROS comes standard with lower linkage coupling point pins of Cat. II, III N and III. The pins are adjustable in length and height. An optional lower linkage pin support for Cat. III adds additional stability if needed.

The headstock of the SUPER ALBATROS range features a clevis lower linkage coupling connection with Cat. III N, III and IV N to match high horsepower tractors. A short conical pivot pin of either 100 mm (ALBATROS) or 120 mm (SUPER ALBATROS) diameter with an adjustable, large tapered roller bearing connects the headstock with the frame. It absorbs all radial and axial loads, minimizes play and wear, guarantees a smooth rollover and supports a trouble free performance of the plough for years.

ALBATROS | SUPER ALBATROS

## PULL POINT ADJUSTMENT AND RE-ALIGNMENT CYLINDER – PRECISE GEOMETRY MAKES THE DIFFERENCE.

### One unit that pays off.

A precise matching of tractor and plough is the key to get the most out of your unit. The accurate pull point setting is the first step to let your plough running precisely behind your tractor – the assumption to add less stress to all components. This causes a tremendous impact on performance, uptime and overall cost of operation and guarantee a trouble free performance over years. This is where RABE adds value to your operation better than anyone else.

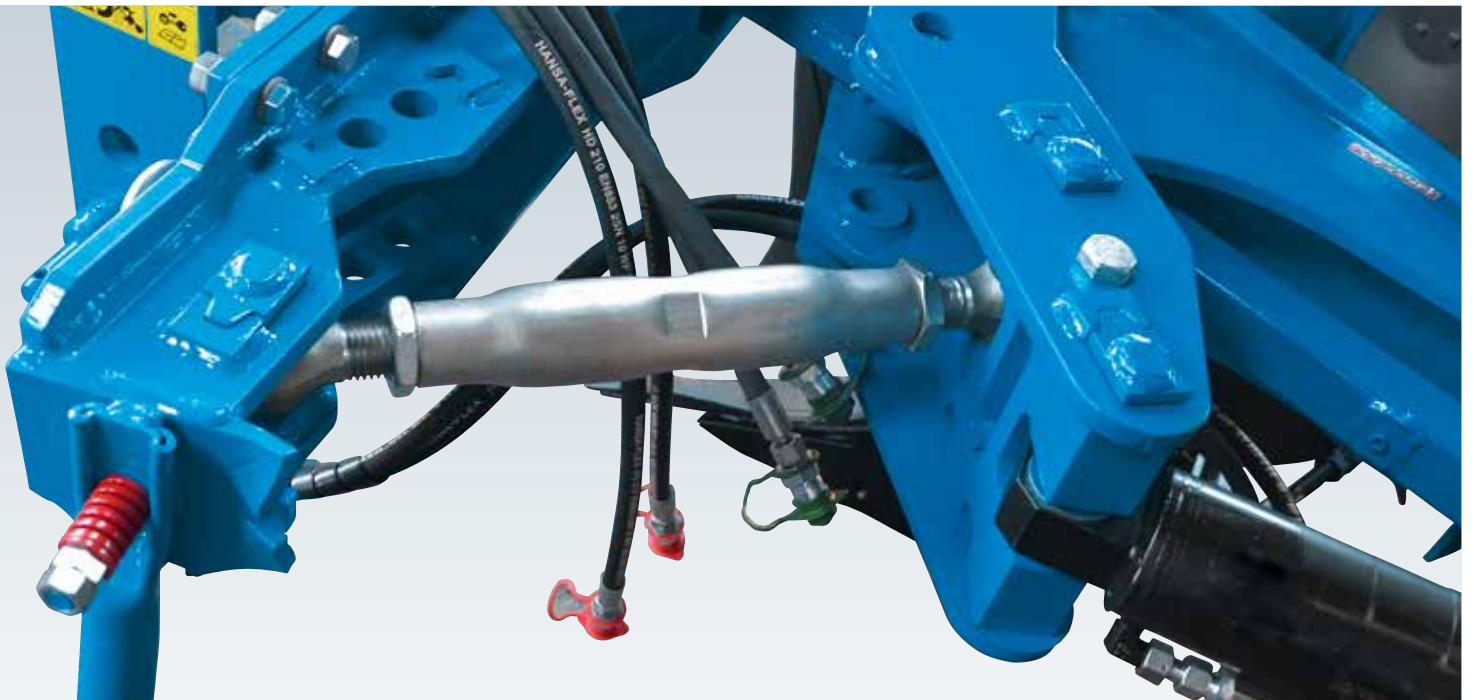

### Pull Point Adjustment

The angle between headstock and frame is adjusted by a turnbuckle. Once set it ensures plough and tractor running straight in the furrow with enough free play at the lower linkage lift arms to reduce side forces causing excessive wear, improve traction and lower the fuel consumption of the tractor.



### Hydraulic Realignment

The hydraulic realignment cylinder moves the centre of gravity to the centre of the plough axis and increases the ground clearance during rollover. It reduces stress on the plough, tractor and rollover mechanism when rolling over and increases stability on hilly fields and supports tractors with limited lift heights.

## FRONT FURROW ADJUSTMENT – SOLUTIONS TO MAKE YOUR JOB MORE COMFORTABLE.

### Two simple solutions for two different demands.

Setting the first furrow can easily be made through a slider with parallel adjustment. While the hydraulic adjustment gives you more comfort mechanical adjustment is even as easy. Once set to match the track width and tractor tyre size you can leave it as it is.

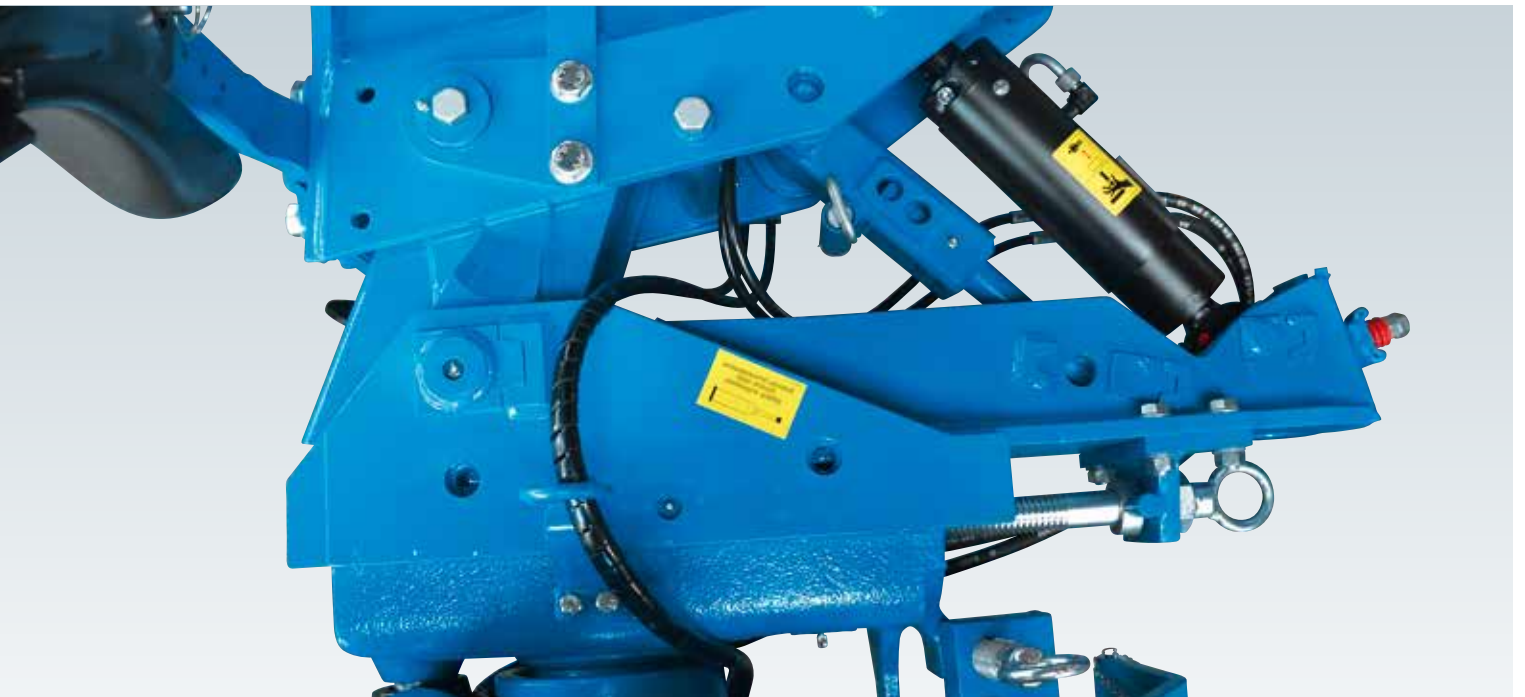

### Mechanic first furrow adjustment

Setting the first furrow can easily be made through a slider with parallel adjustment. The mechanical adjustment is easy. Once set to match the track width and tractor tyre size you can leave it as it is. No need to readjust the pull point to make sure the plough runs straight behind the tractor.

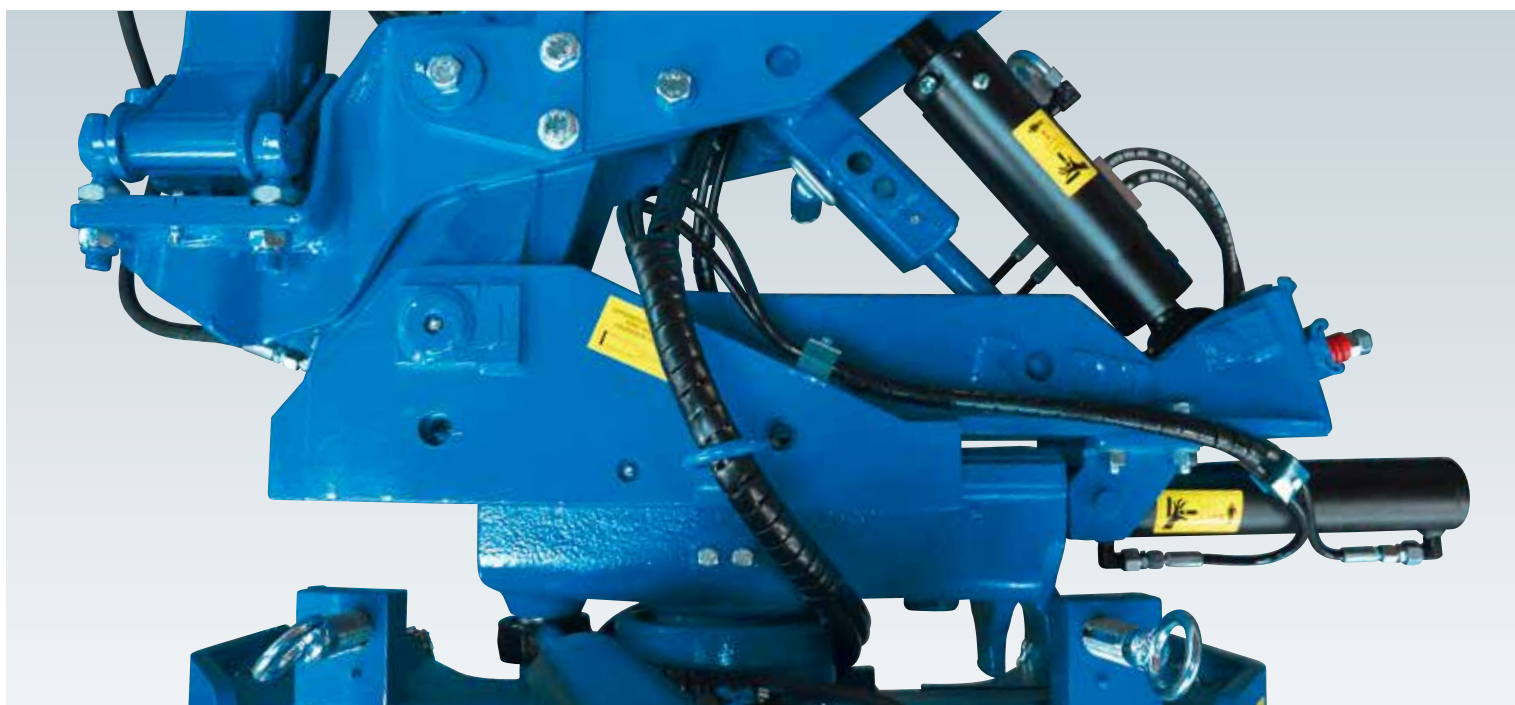

### Hydraulic first furrow adjustment

Hydraulic first furrow adjustment allows you to adjust easily from your tractor's cabin. Recommended when ploughing on changing conditions, hilly fields or different tractors. First furrow adjusting does not touch the pull point setting. For tractors with extra wide tyres or double tyres we offer a longer slider with extended adjustment range.

# WORKING WIDTH – FIXED OR VARIANT.

## RABE consoles – more design than you see.

First, every console gives you flexibility to optimize your plough to your needs. You have the choice between two versions:

- + The standard console offers 4 steps of working width: 35 cm, 40 cm, 45 cm, 50 cm
- + The Vario console enables infinitely variable settings inbetween 33 cm and 53 cm.

Changing the working width of the plough can be done as fast as easy on-the-go with the Vario option. Reducing the working width allows you to overcome tough conditions and quickly change back to maximum productivity without leaving the cab. In addition you can control the field finish and ensure a rougher surface when ploughing in fall and a fine finish when ploughing in spring.



### Variant Console

When choosing the vario console, the width of each body can be set infinitely from 33 cm – 53 cm. The push rod is equipped with special bushings that allow friction only at the greased points for reduced wear. Adjusting the working width is not effecting the pull point. This saves time and ensures reduced pulling requirements. During turnover the cutting width adjustment remains untouched – no memory cylinder is used!



### Console

The console provides connection between frame and leg with mouldboard. It features a long design with a smooth surface for a high contact pressure to transfer loads evenly into the main frame without selective weak points. It's made from hardened tempered material to ensure superior stability and maximum torsion stiffness. The bodies are mounted sidelong the frame for an improved underbeam clearance to avoid the risk of plugging. The working width can be adjusted in four steps from 35 cm – 50 cm.



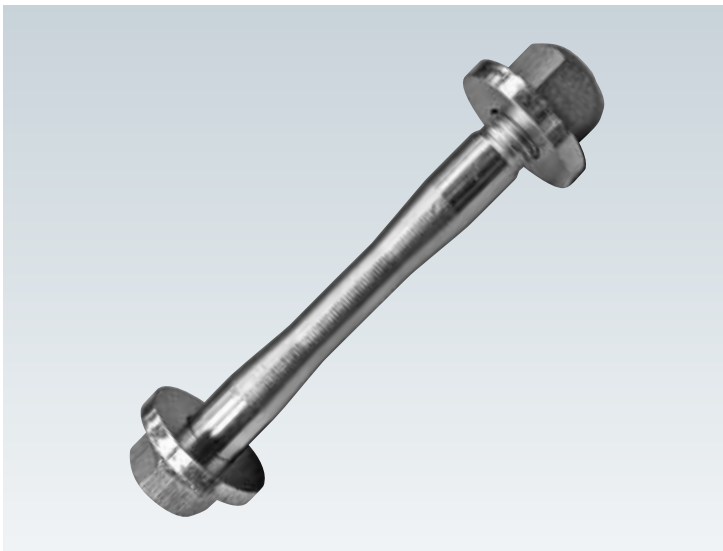

### Pre-stressed fitted bolts

A pre-stressed fitted bolt provides an extremely tight, clearance free connection between the console and the frame with almost no tolerances for minimized wear. Due to the tapered design of the bolt it can be removed easily to change the cutting width manually.

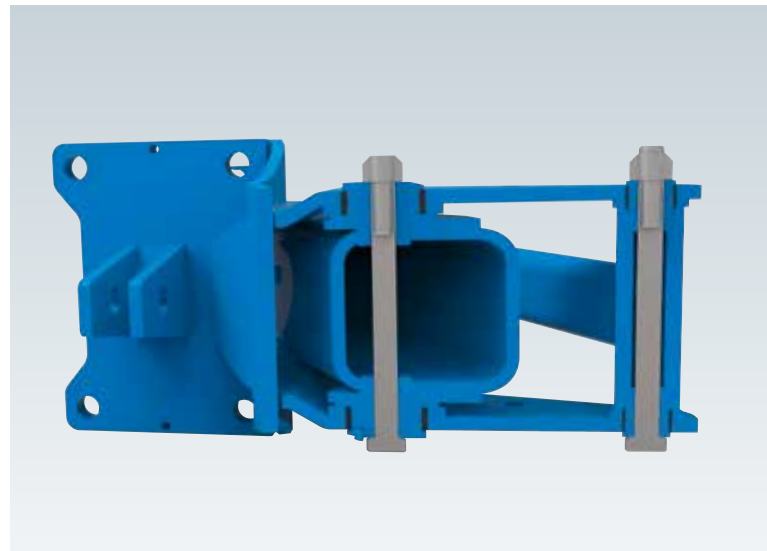

### Bushings

Bushings inside the console provide high stability, no deflection and no clearance. They reduce maintenance costs: when worn out, the bushing only need to be replaced. This increases uptime and reduces cost.

# SHEAR BOLT OVERLOAD PROTECTION – PROTECTING YOUR PLOUGH.

## Shear Bolt Overload Protection.

All RABE ALBATROS and SUPER ALBATROS mounted rollover ploughs come standard with a single side mounted leg and a shear bolt overload protection. It gives you the secure feeling to avoid serious damage on frame, console, leg and body when working in heavy soils without or just a few stones. The unilateral leg mounting and the grooved shear bolt provide the following advantages:

- + Tight connection between leg and console due to a smooth flange and tensioning with special torque
- + Supports a proper shearing of the bolt with a smooth breaking edge
- + Minimizes the risk to seize at a lateral force effect



## Leg Re-inforcement

For heavier conditions such as hard, dry soils without many stones and deep ploughing a leg reinforcement is available. It adds additional strength to the leg and console and guides the leg in an optimum way as soon as higher lateral forces occur. It can be an option specifically for the first mouldboard.



### Shear Bolt

Depending on which specification has been selected, without or with leg re-inforcement, the shear bolt either is equipped with a single or double groove. Both versions support a proper shearing with a smooth breaking edge on the bolt. This allows you to replace a broken bolt quick and easy with less downtime.

# HYDRO AVANT NON-STOP OVERLOAD PROTECTION – ADDING PRODUCTIVITY IN TOUGH CONDITIONS.

## Superior performance and increased uptime in stony fields.

For heavy, stony condition RABE offers a 3D non-stop overload protection to prevent serious damage from the mouldboards. Each pair of mouldboards is connected to a hydraulic cylinder with a separate nitrogen accumulator. The special HYDRO AVANT design allows the mouldboards to avoid obstacles by moving upwards or to the side. The release force can be adjusted easily during work from the tractor cab.

For extra protection, for instance a share is caught by tree roots every mouldboard has an additionally shear bolt.



### State-of-the-Art HYDRO AVANT design

The 4-point mounting allows the HA console to trip vertically and horizontally with a maximum trip height of 340 mm. Special washers and conical bushings integrated into the design ensure superior guidance and proper and fast return into working mode.

- + The HA console is made from high quality hardened and tempered steel for a minimum weight increase
- + No compromises on under beam clearance for a superior residue flow
- + The trip force can be adjusted on-the-go by pre-charging a nitrogen accumulator
- + Each pair of bodies is equipped with an own accumulator
- + Tripping of one body does not effect the other bodies

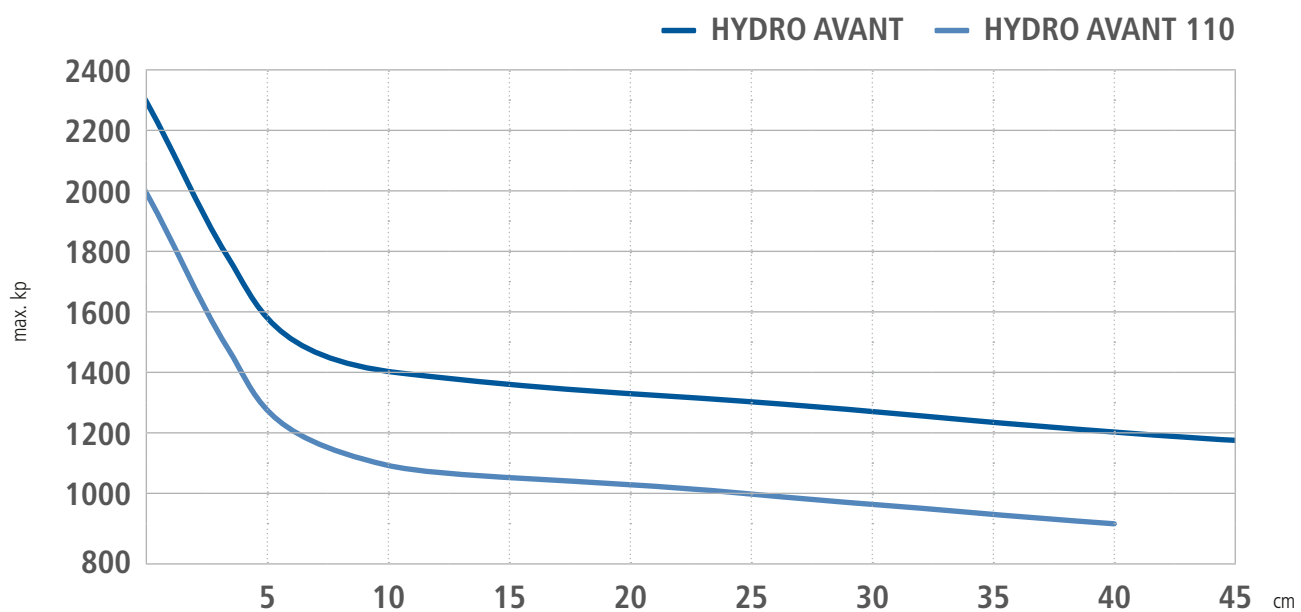

### Force Progression

The patented design of the RABE HYDRO AVANT non-stop security device delivers maximum downforce in working position and a strongly decreasing reset force with increasing trip height. This guarantees perfect working conditions on the one hand and the quickes and safest evasive manoeuvre on the other.

# ALBATROS | SUPER ALBATROS PACKER ATTACHMENTS TO HELP REDUCING COST.

## A step towards a well prepared seedbed.

Our customers can select from a range of different side packers for ploughs to meet their individual needs. (Additional front packers for seedbed preparation can be found in our seeding brochure.)



### Standard Packer Arm

The standard packer arm is recommended for smaller ALBATROS ploughs up to 4 furrows. It has a lot of features and advantages of its bigger brother but in a lighter package.

- + Angle adjustment of the arm to match with any different packer
- + Coiled spring suspension for a smooth packer catching
- + Hydraulic release on-the-go

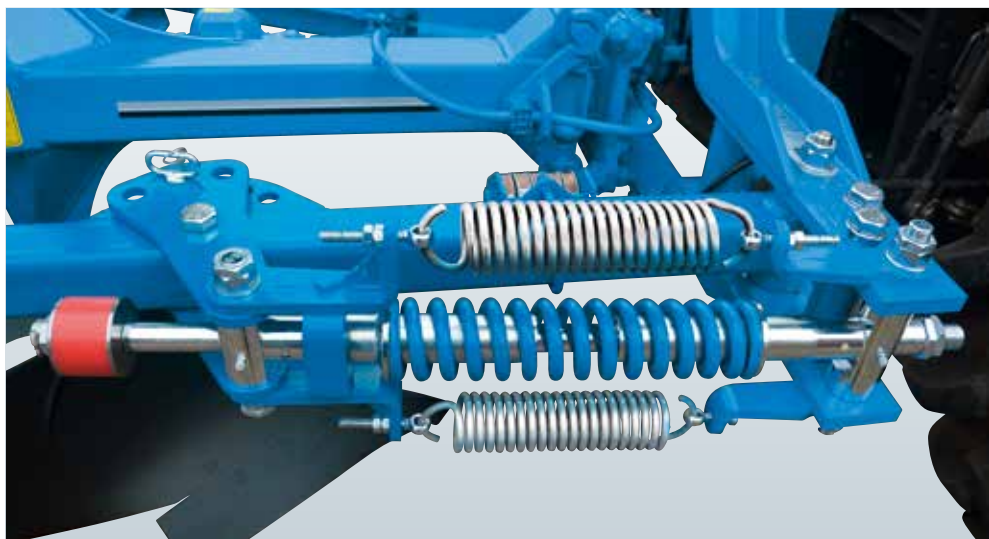

### Heavy Duty Packer Arm

For ploughs of 5 furrows and more or heavier conditions the heavy duty packer arm is the best choice. The unique design of a coil spring package in combination with a shock absorber soaks up any push and pull movements when catching the packer. The smaller springs holds the arm in place and allows the packer to be pulled close to the plough as soon as caught. The result:

- + Superior directional stability of the tractor
- + Almost no side pull
- + Less stress applied to plough and arm when catching the packer
- + More space between packer arm and plough before catching

**CONDOR**

# HEAVY DUTY MOUNTED ON-LAND PLOUGHS FOR TRACTORS UP TO 300 HORSEPOWER.

## On-land ploughing in a compact 3-point mounted package.

The CONDOR has been designed specifically for customers who require high productive on-land ploughing combined with a versatilely mounted plough for smaller and irregularly shaped fields.



For additional advantages of the CONDOR please see also:

- + Console ..... Page 16
- + Shear bolt overload protection and shear bolts ..... Page 18/19
- + Leg re-inforcement ..... Page 18

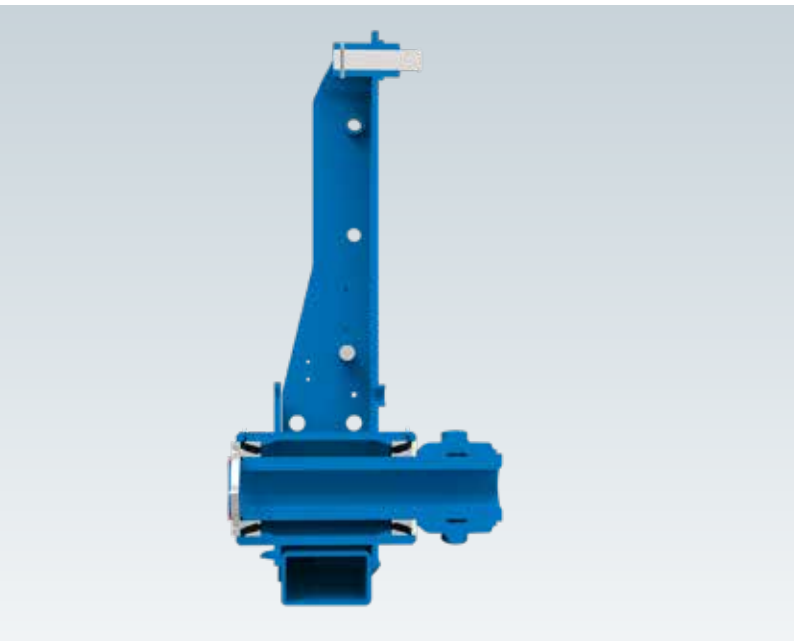

### Robust Headstock Design

The heavy duty headstock puts the CONDOR further ahead of the field. With it's 140 mm pivot it can handle the heaviest configurations up to 7 furrows easily but integrates seamlessly into the overall frame design with compact measurements.

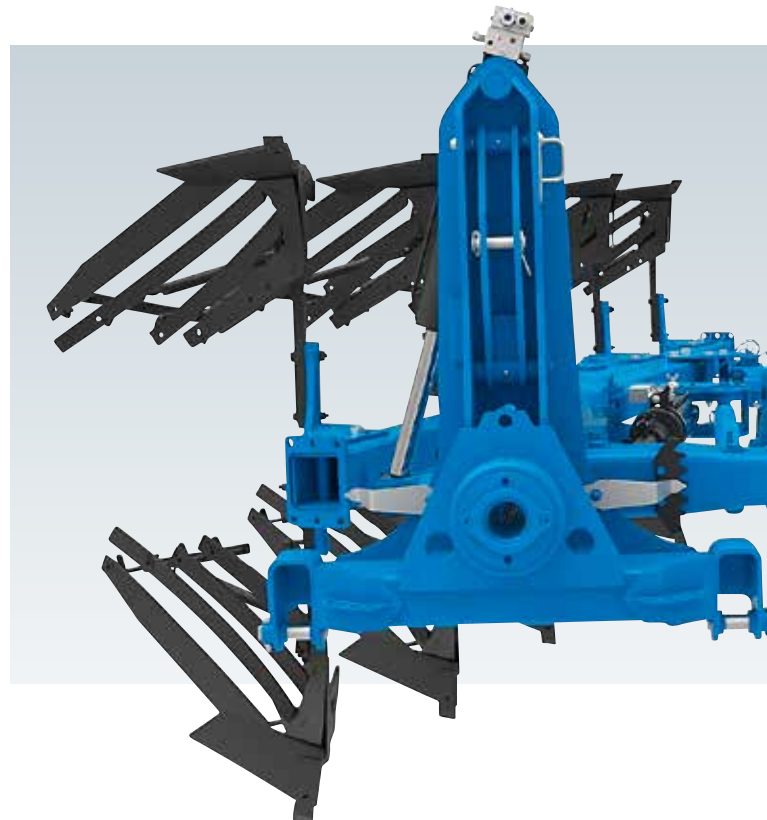





### Suspended Headstock

The headstock of the CONDOR is available with a headstock suspension. With 6 or 7 furrows it is delivered in standard.

- + Absorbs any shocks transferred to the headstock, rollover mechanism and frame
- + Minimizes serious stress on plough and tractor
- + Works on the road and in the field
- + Fully integrated into the design of the headstock
- + Does not increase the overall length of the plough



### Cast Iron Lower Linkage Coupling Points

The lower linkage clevis coupling connections are made from cast iron to ensure a robust connection between plough and high horsepower tractors. Standard tractors with either category III, IV N\* or track tractors with Cat. IV reinforced US quick coupler\* can be connected.

CONDOR

## FRAME DESIGN AND FIRST FURROW ADJUSTMENT.

### Made for the Extreme – Designed to last.

Ploughing on-land with a mounted plough very often means tough conditions where an in-furrow plough or a larger semi-mounted rollover plough is not the ideal solution. This exactly is the field where the CONDOR is made for and delivers its advantages. His thorough design with years of ploughing experience in mind makes him the most reliable and perfect choice for this specific customer segment.

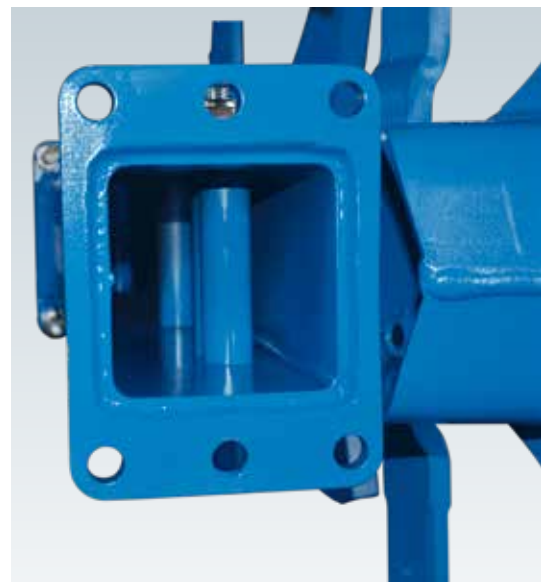

### Hydraulic first furrow cutting width adjustment

All CONDOR are equipped with the hydraulic first furrow adjustment in base. The parallelogram design provides additional strength to the plough and allows customers to quickly adjust to different tractor tyre sizes and track width when ploughing in-furrow or on-land. The possibility of moving quickly to the narrowest width before starting the rollover process in addition avoids serious stress on tractor and plough.



### Integrated frame bushings

Integrated frame bushings provide additional strength to the frame structure where needed and support a tight clamping of the consoles with special body-fit bolts. They completely eliminate any tolerances and facilitate a fast and easy mechanical width of cut adjustment when needed even after years of operation in heavy duty conditions.



### Thorough Frame Design

Three different robust base frames with 150 by 150 mm square tubes can be upgraded from 4 to 7 furrows to meet different tractor horsepower ranges and field conditions. The 4, 5 and 6 furrow base frames allow each to add one more pair of bodies. 90 cm inter body distance and 80 cm under beam clearance keep the plough compact and ensure a trouble free residue flow even in tough field conditions.

# ALBATROS | SUPER ALBATROS | CONDOR WHEELS FOR MOUNTED ROLLOVER PLOUGHS.

## Controlling your ploughing depth more accurately.

Depth wheels definitely can help to control the desired and even depth from the first to the last bottom more accurately.

The D30 with mechanical depth control is definitely a wheel that combines two applications in one and allows a fast conversion from road to field mode. It's the right choice for larger and heavier mounted ploughs. When ploughing depth often is changing a version with hydraulic depth control is also available.



### D30 Combination Transport/Depth Wheel

For more convenience and when ploughing depth needs to be changed very often in one field we recommend the D30 with hydraulic depth control. It delivers the same advantages as the D30 with mechanical depth control but allows to react fast without leaving the cab as soon as the plough sags in certain soils.



### PS30 Depth Wheel

The PS30 is a pure depth wheel for ploughs of 4–6 furrows. Designed for customers with less road transport. It provides a robust design and ensures a precise guidance. As the D30 it features a wide tire to avoid to sink in light soils and to minimize ground pressure. Both wheels, the PS30 and the D30 come standard with a hydraulic cylinder that actively pushes back the wheel during the rollover process for proper guidance. At the same time it dampens the wheel and reduces stress on the console and frame.



### PS5 Depth Wheel

The PS5 is an entry level depth wheel for smaller ALBATROS ploughs up to 4 furrows. It runs inside the plough dimensions and is easy to adjust. During the rollover it swings automatically backwards before touching the ground to avoid damage and sets the depth accurately for the next row.

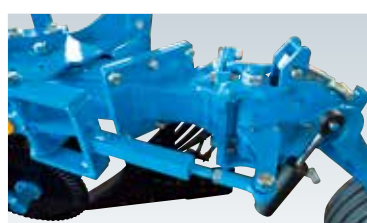

### RJR Depth Wheel

For improved traction and less slippage this depth wheel transfer more weight to the tractor rear axle. Therefore it is mounted in the rear of the plough. The RJR wheel is recommended in lighter conditions where smaller tractors with lighter ploughs are used. With the RJR no lighting can be mounted in the back.

# TECHNICAL DATA MOUNTED ROLLOVER PLOUGHS.

Series	ALBATROS		SUPER ALBATROS		CONDOR
Model	110	120	140	160	150
Configuration	in-furrow				in-furrow /on-land
Frame dimensions (mm)	110 × 110	120 × 120	140 × 140	160 × 160	150 × 150
Under beam clearance (cm)	80		80 or 85	80	
Interbody distance (cm)	100	90 or 100	100 (140 MW = 120 cm)		90
Tractor coupling (Cat.)	II, III, III N		III, III N, IV N		II, IV N, US quick coupler
Number of furrows	3, 4, 5	3, 4, 5, 6	4, 5, 6		4, 5, 6, 7
Max. horsepower (hp)	110 – 150	130 – 200	200 – 300		150 – 300
Cutting width adjustment	mechanical, 4 steps (33–47 cm)	mechanical, 4 steps (35–55 cm) or hydraulic (33–52 cm)			
First furrow adjustment	mechanical or hydraulic				hydraulic
Rollover mechanism	hydraulic				
Mouldboards	plain or slatted				
Mouldboard overload protection	shear bolt or hydraulic non-stop				
Points	PLASMABID or reversible point				
Skimmer	round leg or VARI-FIX				
Skimmer overload protection	option with shear bolt (only VARI-FIX, not available for 90 cm point to point distance)				not available
Trashboards	option (instead of skimmers)				
Rear Depth Wheel	PS5, PS30 or RJR (depends on model and configuration)				PS30
Combination depth/ Transport wheels	D30				
Depth wheels	mechanical	mechanical or hydraulic (hydraulic not for the RJR wheel)			
Knife coulter	option				
Disc coulter	option (wavy or notched disc, rigid or spring-loaded design, 500 mm)				
Subsoiler	option				
Road lights	option (not in combination with the RJR wheel)				option



**KORMORAN**

# SEMI-MOUNTED ROLLOVER PLOUGHS – SOLUTIONS THAT PAY.

## Delivering Impressive performance every step of the way.

KORMORAN semi-mounted in-furrow and on-land rollover ploughs have been designed from bottom up with passion and long term experience in designing and manufacturing rollover ploughs.



### **KORMORAN SF**

The KORMORAN SF is an easy to use and reliable entry level semi-mounted rollover plough. Ideal for customers who want to plough in-furrow with maximum 8 furrows and light to medium soil conditions. It comes standard with a front furrow width of cut adjustment with a slider. Customers can choose between a shear bolt or the HYDRO AVANT non-stop overload protection.



## KORMORAN PF

The KORMORAN PF is the ultimate choice in tough field conditions to add maximum productivity to your operation with up to 9 furrows (depending on the configuration). It features a hydraulic cutting width adjustment with a parallelogram arm in base for increased durability. To offer superior versatility it can be ordered optionally with a variable adjustment of working width and a HYDRO AVANT non-stop overload protection.



## KORMORAN PL

The KORMORAN PL combines high performance with maximum versatility. Whatever your specific field conditions demand: for full grip you can plough in-furrow or on-land and use high horsepower tractors with wide tyres.

# KORMORAN SF | KORMORAN PF/PL

## ONE RANGE – TWO MODELS: THE KORMORAN SF AND THE KORMORAN PF/PL.

### KORMORAN SF



#### First furrow adjustment SF

The slider of the SF allows a fast and convenient adjustment of the front furrow width of cut adjustment, either mechanically or hydraulically.



#### Transport/Depth Wheel SF

The SF is delivered in base with a low pressure trailer profile tyre 500/45-22.5 with a diameter of 1035mm. A slightly taller tyre, 16.0/70-R20 with a tractor profile is available, too for convenient depth control. Both wheels are suspended to ensure gentle road transport with less stress on the plough.



#### Round Tube Support Frame

The large diameter, round tube support frame gives additional strength to the frame and provides the connections between frame and wheel. Depending on the configuration it can be extended with an additional body in the front.

## KORMORAN PF / PL

### Hydraulic first furrow adjustment PF / PL

The PF and PL models come standard with a hydraulic front furrow adjustment with a parallelogram linkage to ensure maximum rigidity in tough conditions. It provides the necessary offset for tractors with wider tyres and larger footprints when ploughing in furrow and particularly on-land.



### Transport/Depth Wheel PF / PL

The 17.5 × 24 AS tyre with tractor tyre profile measures a diameter of 1220 mm. It provides serious advantages in uneven terrain and rough field conditions and keeps the plough at a consistent depth. As the wheels of the SF, it offers a suspension for a comfortable road transport.



### Square Tube Support Frame

The parallelogram linkage and the main frame of the PF and PL requires a strong support, specifically for tractors with a wide track width or when ploughing on-land, due to the wide frame offset. Therefore these ploughs are equipped with a large diameter square tube to take stress away from the main frame, support the wheel and carry the load during road transport.



### Front Furrow Depth Wheels

The front furrow depth wheels, base equipment on all PL on-land ploughs, guide the entire plow properly in the furrow and support driving a straight track when working manually without any guidance system.



# FEATURES AND HIGHLIGHTS.

## Rack and Pinion

Supports a smooth and continuous rollover of the plough when turning at the headland with less stress applied to the headstock and frame.

» Details see page 39

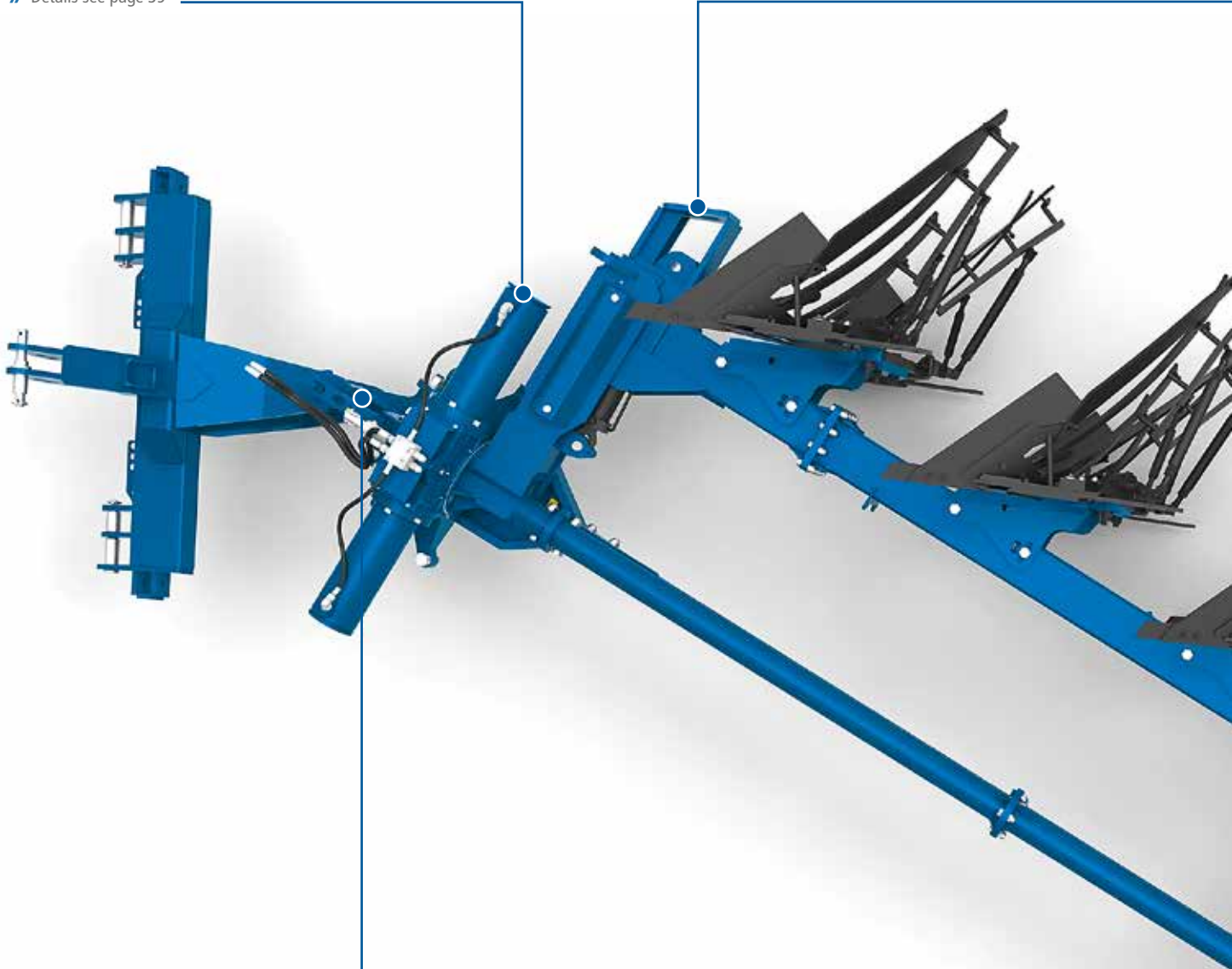

## 110° Turning

The hinge connecting the headstock with the frame allows a 110° turning angle for sharp turning on field corners.

» Details see page 38

## Z-Frame

Allows wheel to stay within the overall plough dimensions for ploughing sharp at field edges and keeps the center of gravity as low as possible for more stability on the road.

» Details see page 40

## Frame Design prepared for a Packer Arm

All KORMORAN in-furrow and on-land ploughs are prepared to fit a packer arm to combine applications and leave a well prepared field.

» Details see page 41

## Integrated frame bushings

Provide additional strength to the frame structure where needed and support a tight clamping of the consoles without any tolerances.

» Details see page 40

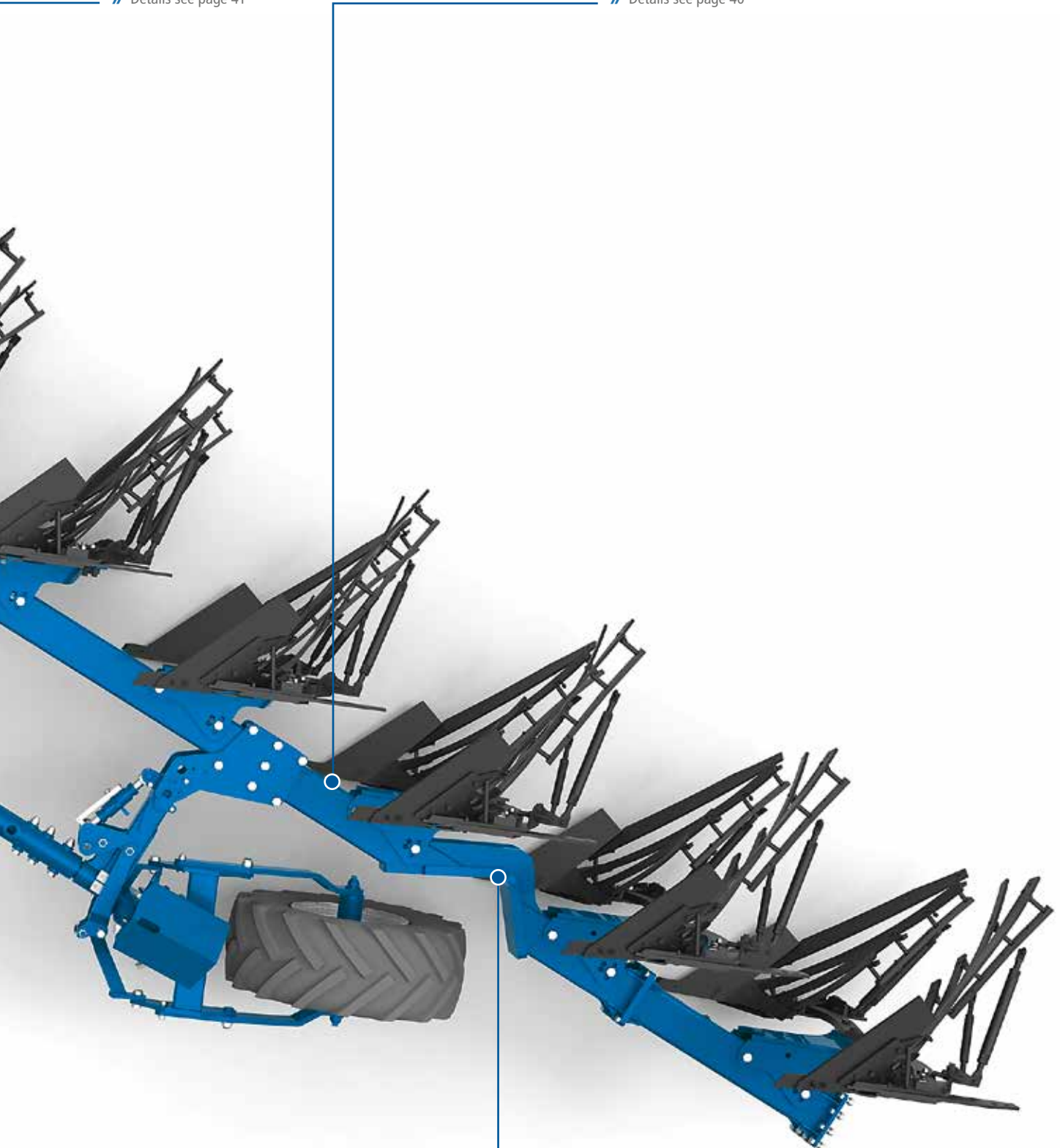

**KORMORAN**

# HEADSTOCK AND ROLLOVER MECHANISM – BOOSTING PERFORMANCE.

## Setting Directions.

KORMORAN in-furrow and on-land semi-mounted rollover ploughs address our most demanding customers when it comes to cover as many hectares as possible in a given and short ploughing window. They set a new standard when it comes to superior performance, maximum uptime and low cost of operation.

- + Solid frame design
- + Innovative headstock
- + State-of-the-Art rollover mechanism



For additional advantages of the KORMORAN please see also:

- + Shear bolt overload protection and shear bolts ..... Page 18/19
- + Leg re-inforcement ..... Page 18
- + HYDRO AVANT non-stop overload protection ..... Page 20/21

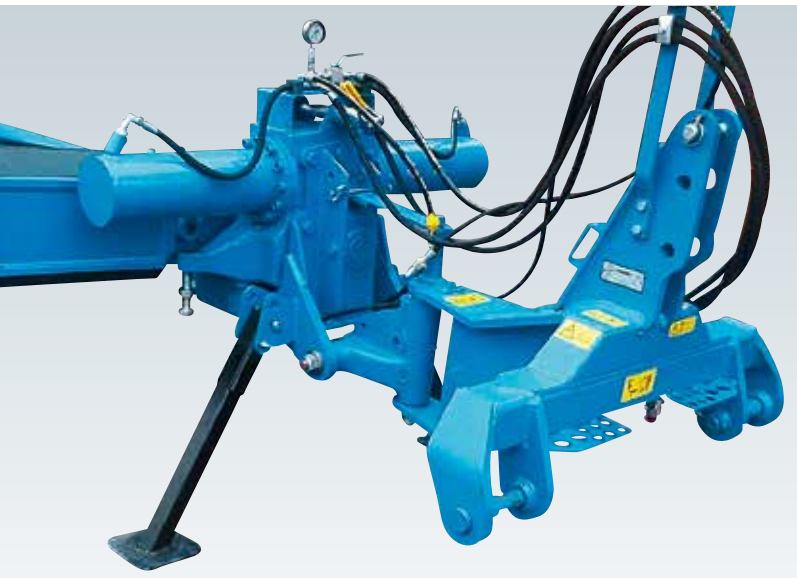

### Headstock

The robust headstock features combined Cat. III/IV N coupling connections for the lower linkage lift arms and the top link to meet various tractor sizes. The overall design supports an easy and fast connection to the tractor with enough space but also mounts close to the tractor rear axle to keep the overall length of the entire combination compact to handle smaller field and narrow headlands better.



### 110° Turning

All KORMORAN semi mounted ploughs are delivered in base with a hinge to connect the headstock with the frame that allows a 110° turning angle. It supports extremely sharp turning particularly on narrow headlands and easy backing up into tight corners on smaller fields.

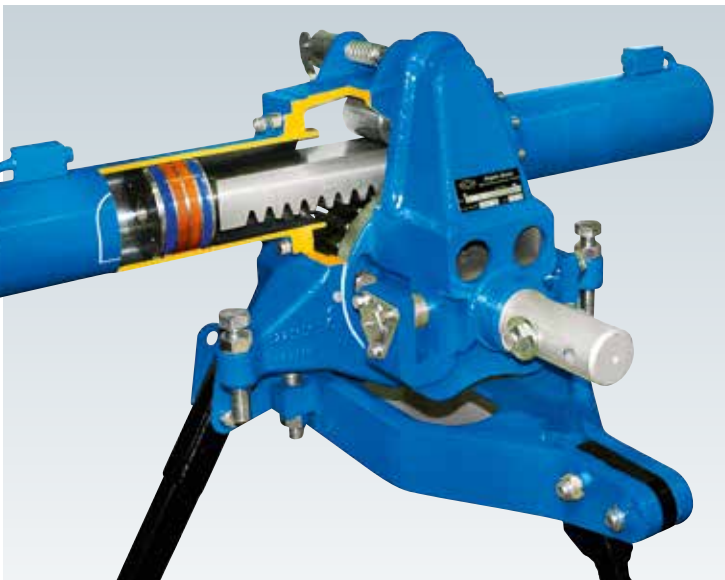

### Rack and Pinion

The state-of-the-art Rack and Pinion rollover mechanism supports a smooth rollover of the plow when turning at the headland with less stress applied to the headstock and frame. It allows starting, stopping and continuing the rollover process at any point. There is no dead spot in the rollover process like on many other systems that operate with two hydraulic cylinders. In addition you can steer the rear wheel or carriage to backup into tight corners easily.



### Traction Control

To ensure maximum traction with minimum wheel slippage the KORMORAN can be equipped with a traction control system as option. It allows to transfer more weight to the front and rear axle of the tractor to reduce fuel consumption and improve overall efficiency when ploughing in heavy duty field conditions.

**KORMORAN**

# FRAME DESIGN – INCREASING UPTIME.

## Making a big rigid frame agile.

Listening carefully to large and extra large arable farms that are looking at the most productive single wheel semi-mounted plough, the KORMORAN has been designed with utmost reliability and versatility in mind. Clever design features make the KORMORAN agile and resembles a mounted plough more than a semi mounted one.



### Z-Frame

The unique Z-frame design allows the wheel to stay within the plough working width. This enables to plough exactly to the edge of the field. And during transport the plough can be lowered even deeper to keep the center of gravity as low as possible for more stability on the road.

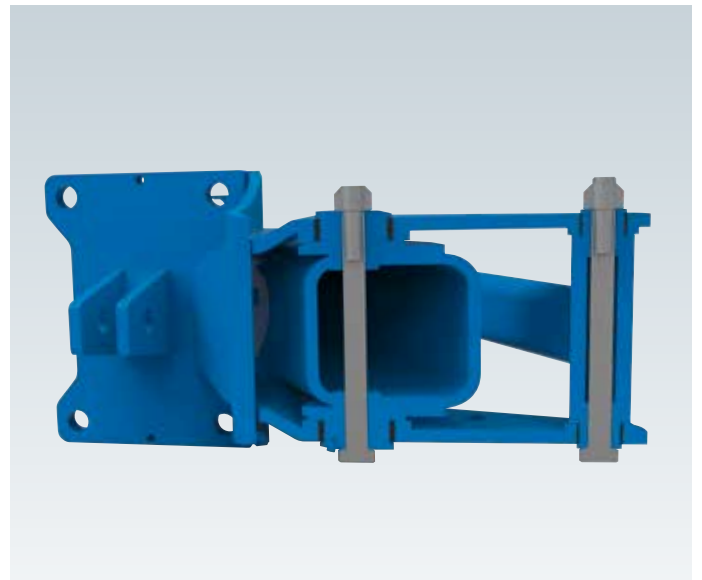

### Integrated frame bushings

Integrated frame bushings provide additional strength to the frame structure where needed and support a tight clamping of the consoles with special body-fit bolts. They completely eliminate any tolerances and facilitate a fast and easy mechanical width of cut adjustment when needed even after years of operation in heavy duty conditions.





### Packer Arm

The all new packer arm ensures superior directional stability of the tractor, almost no side pull, less stress applied to plough and arm when catching the packer, and more space between packer arm and packer before catching.



### Frame Extension

All KORMORAN, except the 5 furrow, come standard with a pair of bodies behind the Z-structure to allow sharp border ploughing. In addition the pair of bodies behind the wheel supports a well balanced plough for most accurate ploughing with low fuel consumption. In case of conditions become extremely tough in fall, this additional pair of bodies can be quickly removed to make sure ploughing can be finished in time.

**KORMORAN**

# WORKING WIDTH – FIXED OR VARIANT.

## Meeting your individual needs even better

Delivering maximum rigidity and strength whatever the individual specification looks like is truly key for every plough but adding versatility is always a matter of what individual customers desire. RABE ploughs have the flexibility our customers deserve.

- + Manual working width adjustment in 4 steps from 35, 40, 45 and 50 cm
- + Infinitely adjustment of cutting width from 35 to 50 cm, hydraulically controlled from tractor cab

Changing the working width of the plough can be done as fast as easy on-the-go with the Vario option. Reducing the working width allows you to overcome tough conditions and quickly change back to maximum productivity without leaving the cab. In addition you can control the field finish and ensure a rougher surface when ploughing in fall and a fine finish when ploughing in spring.



### Variant-Console

When choosing the Variant cutting width adjustment the width of each body can be set infinitely from 35–50 cm on-the-go for a convenient operation and to quickly adapt to changing conditions. Whether you choose the mechanical or the infinitely variable width of cut adjustment, all consoles are made from hardened tempered material to ensure superior stability and maximum torsion stiffness.



### Console

The console provides the connection between the leg with the mouldboard and the frame. The long design with a smooth surface for a high contact pressure transfers the load evenly into the main frame. The cutting width can be adjusted mechanically in four steps 35–40–45–50 cm.



### Push Rod and Variant Hydraulic Cylinder

By changing the hydraulic pressure from the tractor cab the cutting width can be adjusted. The Variant hydraulic cylinder moves and controls the position of all bodies which are connected by push rods. At the same time the cylinder aligns the wheel always parallel to the bodies. All connections and hinges between the push rods feature bushings to ensure an equal cutting width between all bodies with minimum tolerances and no clearance, even after years of operation.

**KORMORAN**

# WHEELS – GENTLE TRAVEL ON THE ROAD, ACCURATE DEPTH CONTROL IN THE FIELD.

## **KORMORAN SF Wheel 500/45-22.5**

- » Width 500 mm
- » Diameter 1035 mm
- » Rolling Circumference 3167 mm
- » Load Capacity (30 km/h) 4200 kg
- » max. tyre pressure 3.6 bar



## **KORMORAN SF Wheel 16.0/70-R20**

- » Width 408 mm
- » Diameter 1097 mm
- » Rolling Circumference 3214 mm
- » Load Capacity (25 km/h) 3940 kg
- » max. tyre pressure 3.2 bar





### **KORMORAN PF and PL Wheel 460/70 R24**

- » Width 465 mm
- » Diameter 1254 mm
- » Rolling Circumference 3840 mm
- » Load Capacity (25 km/h) 3940 kg
- » max. tyre pressure 3.2 bar



### **KORMORAN PL front furrow depth wheels**

- » Width 320 mm
- » Diameter 693 mm

**MARABU**

# PEERLESS PRODUCTIVITY, UNMISTAKABLE DURABILITY.

## Striking Performance.

With the MARABU we define machine performance as much more than just power. For us this means peerless productivity and maximum uptime at minimum cost of operation. This fulfills the needs of our most demanding customer better anything else. The MARABU has to be ready to go in the field when the timing is there to meet critical ploughing windows extra-large farms typically have to deal with.



**For additional advantages of the MARABU please see also:**

- + Shear bolt overload protection and shear bolts ..... Page 18/19
- + Leg re-inforcement ..... Page 18
- + HYDRO AVANT non-stop overload protection ..... Page 20/21



## MARABU SF and SL

Whether you want to plough in the furrow or being more flexible and plough in the furrow or on-land, with the MARABU you have the choice. Both models are available from 7 to 12 furrows. The massive carriage with large flotation tyres precisely keep the desired ploughing depth. The integrated frame hinge provides the necessary flexibility to withstand the toughest conditions.

# FEATURES AND HIGHLIGHTS.

## Trailed Lifter (optional)

Features a carriage with an own 3-point linkage system to connect the plough to tractors without own 3-point linkage system.

» Details see page 52

## Front Depth Wheels (Onland Version)

Guide the entire plough properly in the furrow and support driving a straight track when working manually without any guidance system.

» Details see page 52

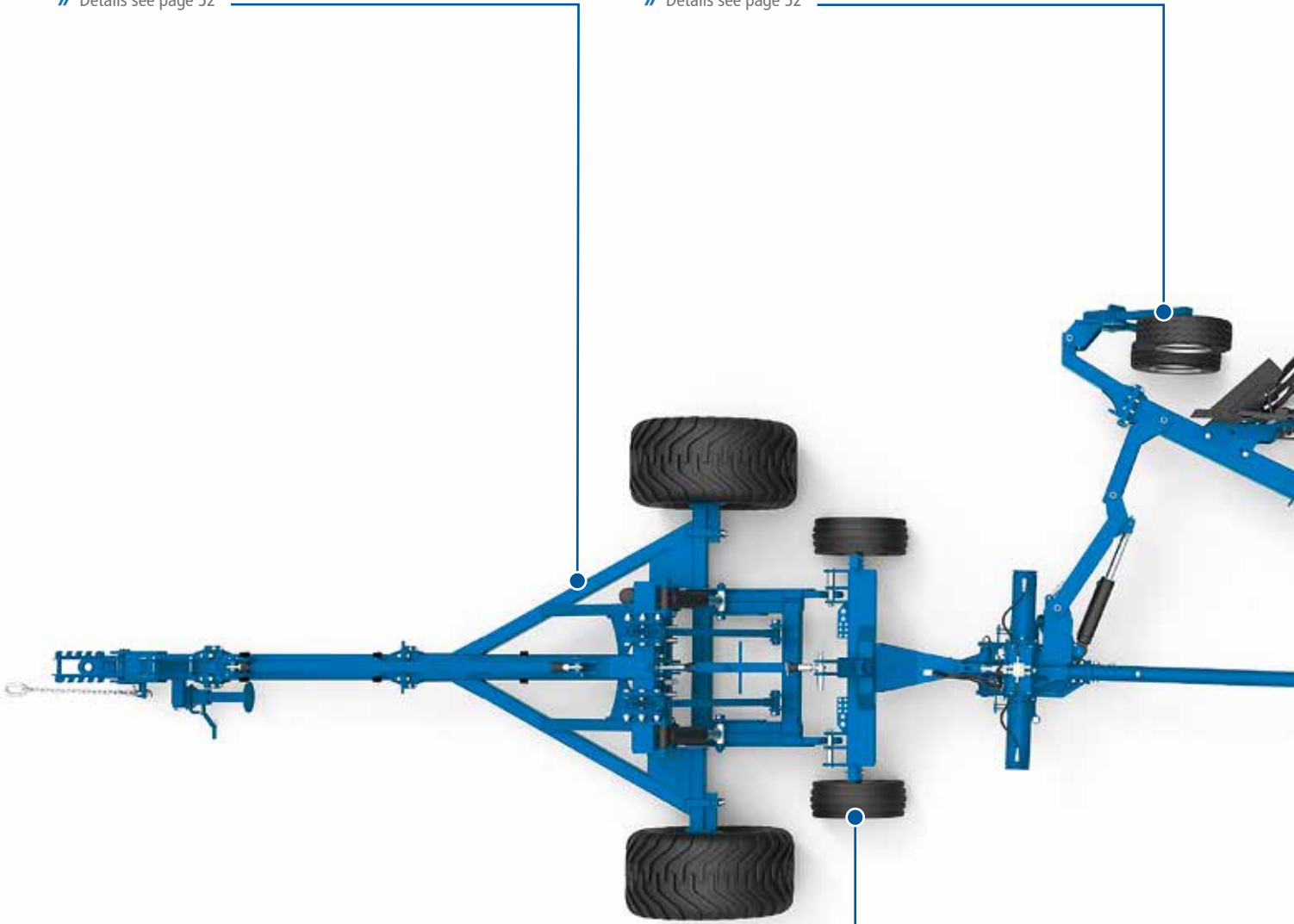

## Depth Wheels for Quick Coupler (optional)

Take some load from the rear axle of the tractor and make sure the tractor runs with maximum traction as soon as crawlers or articulated tractors are used.

» Details see page 52



## Frame Hinge

Allows flexing of the frame behind the carriage for effortless ploughing and less stress applied to the frame in hard, dry soils.

» Details see page 50

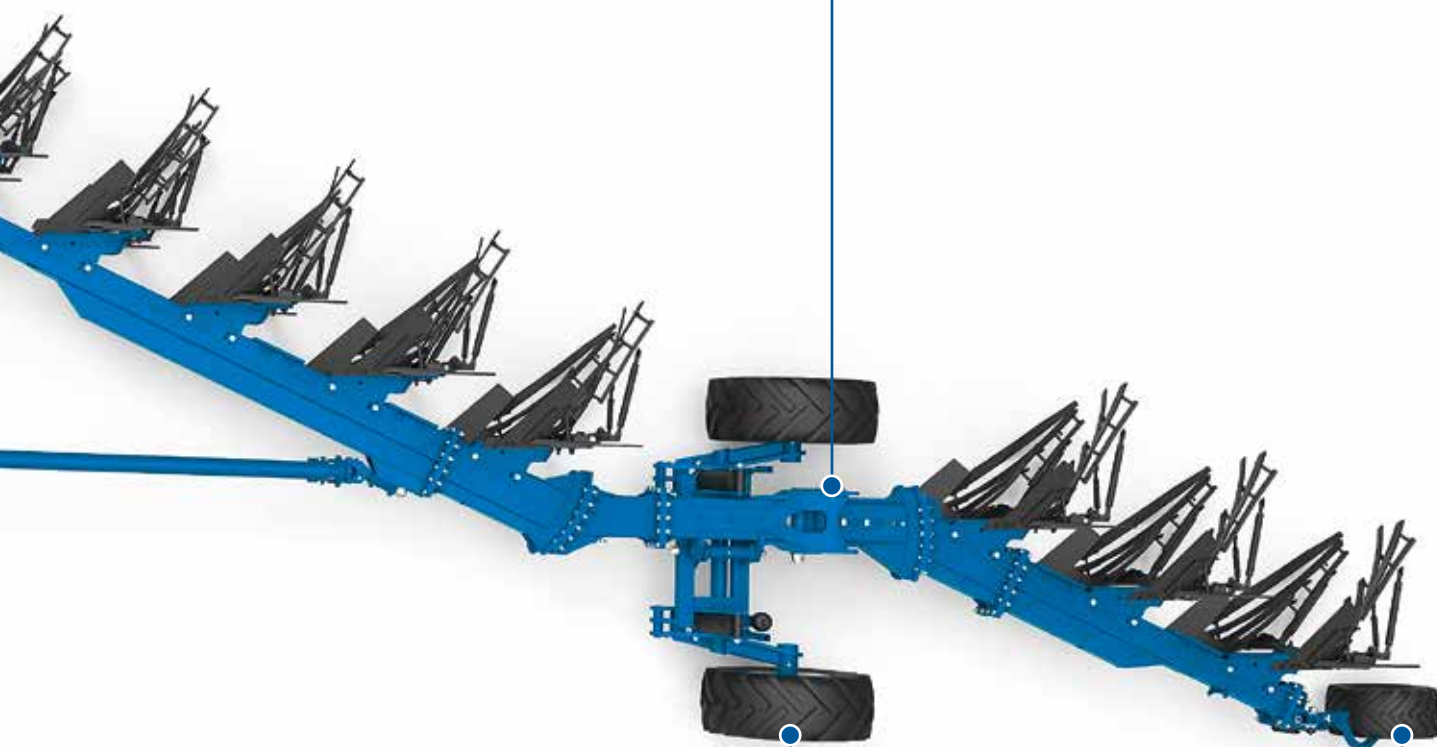

## Central Carriage

Well balanced plough for optimum depth control even with 12 furrows. Perfect weight split between front and rear.

» Details see page 51

## Rear Depth Wheel

Keeps the back part of the plough in perfect ploughing depth.

» Details see page 52

**MARABU**

# SOLID FRAME CONSTRUCTION.

## Robust Frame design.

The entire plough design of the MARABU has been built on a solid frame structure to meet the needs of extra large arable farms. The frame has been made from two pieces connected by a strong hinge and supported by the carriage. The front frame features a 260 by 180mm frame size with a 10mm wall thickness. The rear frame comes standard with a 180 by 180mm frame. For the widest model an additional reinforcement square tube of 100 by 100 mm has been added to carry the load of the plough properly.



### Frame hinge

The frame hinge located at the carriage, allows the bottoms behind the carriage to flex for effortless ploughing and to avoid serious damage on the plough in hard, dry ground. It automatically locks as soon as the plough is lifted at the headland or put in transport position on the road for maximum stability.



### Packer New.

The MARABU now has a tailor-made packer. Two packerrollers (or three, depending on model) are installed to the plough and can be individually adjusted by hydraulic cylinders. An extra cylinder mounted above the carriage supports for turnover at the headlands.



### Central Carriage

The central carriage of the MARABU is capable of holding up to 12 furrows with ease and supports a well-balanced chassis in the field to plough at an even depth particularly with the widest configuration. It provides as much weight as necessary to the rear axle for optimum traction of heavy tractors.

MARABU

# SUPERIOR HANDLING IN THE FIELD AND ON THE ROAD.

## Making your ploughing job a profitable success.

A superior field finish at maximum traction and a low fuel consumption is essential to make your ploughing job an overall success when it comes to performance and cost of operation. It's based on a couple of crucial factors where the RABE MARABU adds value to your operation.

- + Even and most accurate ploughing depth front to rear
- + Superior guidance of the plough in the furrow with less wear
- + Effortless pulling with less side pull



### Front Furrow Depth Wheels

The front furrow depth wheels, base equipment on all MARABU SL onland ploughs, guide the entire plough properly in the furrow and support driving a straight track when working manually without any guidance system.



### Rear Depth Wheel

A depth wheel in the rear assures a consistent ploughing depth along the entire plough. In combination with the central carriage this wheel package provides an extremely well balanced plough when it comes to hilly fields.



### Depth Wheels for Quick Coupler

When crawlers or articulated tractors are used we recommend depth wheels for quick couplers. They take some load from the rear axle of the tractor and make sure the tractor runs with maximum traction. We do also recommend for trailed lifters.



### Trailed Lifter

For tractors without own hydraulic lift system a trailed lifter can be ordered. The trailed lifter features a carriage with a drawbar in the front to connect to the hitch or piton fix of the tractor and a 3-point linkage in the rear to attach the plough. All hydraulic hoses of the plough are directly connected to the trailed lifter.

# ACCESSORIES – MAKING A GOOD PRODUCT EVEN BETTER.

## Electro Hydraulic Selector

An Electro Hydraulic Selector adds convenience to control the plough properly and most efficiently in the field, particularly with sophisticated ploughs and when the tractor is not equipped with enough SCV's. The Electro Hydraulic Selector merges two hydraulic function into one and allows to execute them through only one tractors SCV.



## Road Lights

All KORMORAN and MARABU can be delivered with a road lighting kit as an option for safe road transport even with the widest plough and full specification.



## Working Lights

When ploughing in the dark you will appreciate full illumination of the plough and the surrounding. The MARABU can be optionally ordered with a set of working lights. These are mounted above the carriage and support the working lights of the tractor.



# TECHNICAL DATA

## SEMI MOUNTED ROLLOVER PLOUGHS.











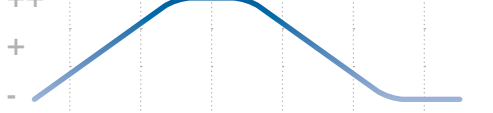

Series	KORMORAN			MARABU	
	SF	PF	PL	SF	SL
Configuration	in-furrow		in-furrow/on-land	in-furrow	in-furrow/on-land
Frame dimensions (mm)	180 × 180			180 × 260 / 180 × 180	
Under beam clearance (cm)	80				
Interbody distance (cm)	100				
Tractor coupling (Cat.)	III, IV N		III/IV N, III/IV US quick coupler		
Number of furrows	5, 6, 7, 8		5, 6, 7, 8, 9	7, 8, 9, 10, 11, 12	
Max. horsepower (hp)	220 – 350		220 – 350	260 – 500	
Cutting width adjustment	mechanical, 4 steps (35 – 55 cm)	mechanical, 4 steps or hydraulic (35 – 55 cm)		mechanical 4 steps (35 – 55 cm)	
First furrow adjustment	mechanical or hydraulic	hydraulic			
Rollover mechanism	rack and pinion				
Mouldboards	plain or slatted				
Mouldboard overload protection	shear bolt or hydraulic non-stop				
Points	PLASMABID or reversible point				
Skimmer	round leg or VARI-FIX				
Skimmer overload protection	option with shear bolt (only VARI-FIX)				
Trashboards	option (instead of skimmers)				
Rear Depth Wheel	not available			base	
Combination depth/ Transport wheels	base (single wheel)			base (carriage)	
Front furrow wheels	not available	base		not available	base
Depth wheels for quick coupler	not available			option	
Knife coulter	option				
Disc coulter	option (wavy or notched disc, rigid or spring-loaded design, 500 mm)				
Subsoiler	option				
Road lights	option				

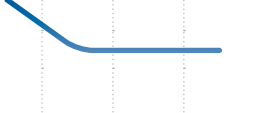

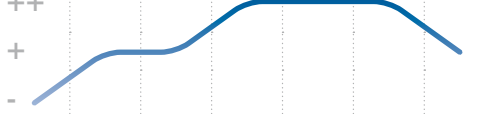
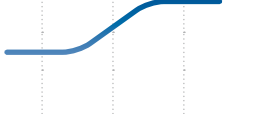
# THE MOULDBOARD MAKES THE DIFFERENCE.

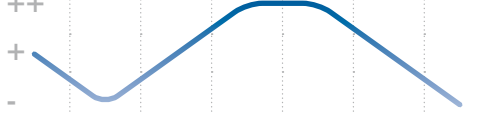
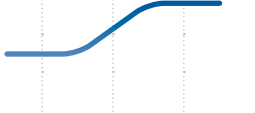
## The right mouldboard for your individual needs.

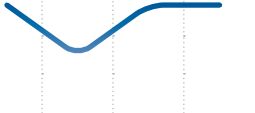
Choosing the right mouldboard has a serious impact on the drag force and the fuel consumption of the tractor, the body wear and finally the ploughing result. We offer plain or slatted mouldboards in several sizes and shapes for every specific soil and condition, residue levels and ploughing depths.

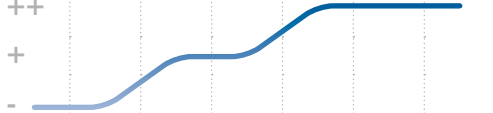
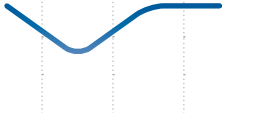
Body Type / Length (inch)	Max. working depth (cm)	Max. working width (cm)	Weight ca. (kg)	Universal Shape	Spiral Shape	Sticky Soil	Sand	Aluvium and Sand	Aluvium	Aluvium and Clay	Potter's Clay	Clay	Furrow Clearing	Crumbling	Pulling Requirement	Turning of Soil
 BP-351 O	40	50	56	•	-	++ + -										
 BP-322 P	38	50	56	•	-	++ + -										
 BP-320 W	30	50	56	-	•	++ + -										
 BP-341 W	35	50	57	-	•	++ + -										
 BP-351 W	35	50	55	-	•	++ + -										
 BP-365 P two-part share	30	50	56	-	•	++ + -										

Suitability: ++ ideal + well - less







### RABE CONIT and RABEDUR

Carbonized mouldboards made from CONIT deliver a hard surface structure and a ductile core for minimized risk of breakage under any condition. CONIT is used on all plain mouldboards, shin protections and the upper slats on slatted mouldboards. RABEDUR delivers an extremely even hardness across the entire material thickness for maximum wear resistance and long life performance. RABEDUR is used on all lower slats on slatted mouldboards.



Slatted mouldboards take advantages in terms of reduced wear, lower drag forces and sticking of soil. It's your choice to select from a wide range of various genuine RABE mouldboard designs. When it comes to very light sandy soils or lots of residue RABE plain mouldboards can offer advantages.

Body Type/Length (inch)	Max. working depth (cm)	Max. working width (cm)	Weight ca. (kg)	Universal Shape	Spiral Shape	Sticky Soil	Sand	Aluvium and Sand	Aluvium	Aluvium and Clay	Potter's Clay	Clay	Furrow Clearing	Crumbling	Pulling Requirement	Turning of Soil
 BP-331 WS	30	50	56	-	•	++	+	+	+	+	-	-	+	+	+	+
 BP-323 PS	38	50	57	•	-	++	+	+	+	+	-	-	+	+	+	+
 BP-355 RS	40	50	55	•	-	++	+	+	+	+	-	-	+	+	+	+
 BP-351 WS	35	50	56	-	•	++	+	+	+	+	-	-	+	+	+	+

Suitability: ++ ideal + well - less



### RABE PLASMABID and Reversible Point.

Customers can choose between the carbide build-up welded share point and a reversible wear point. The reversible wear point is recommended for stony conditions to protect the mouldboard and it is known for slightly better invading the soil. For all other conditions the PLASMABID provides a much higher wear resistance to minimize downtime.

# ENSURING SUPERIOR RESIDUE FLOW.

## Handling organic matter more efficiently.

RABE offers a wide range of various skimmers and trashboards to specifically meet your individual needs when it comes to efficient residue handling during ploughing. To avoid serious damage the VARI-FIX skimmers can be optionally equipped with a shear bolt. The shear bolt safety device is always recommended in rocky conditions in combination with HYDRO AVANT ploughs.

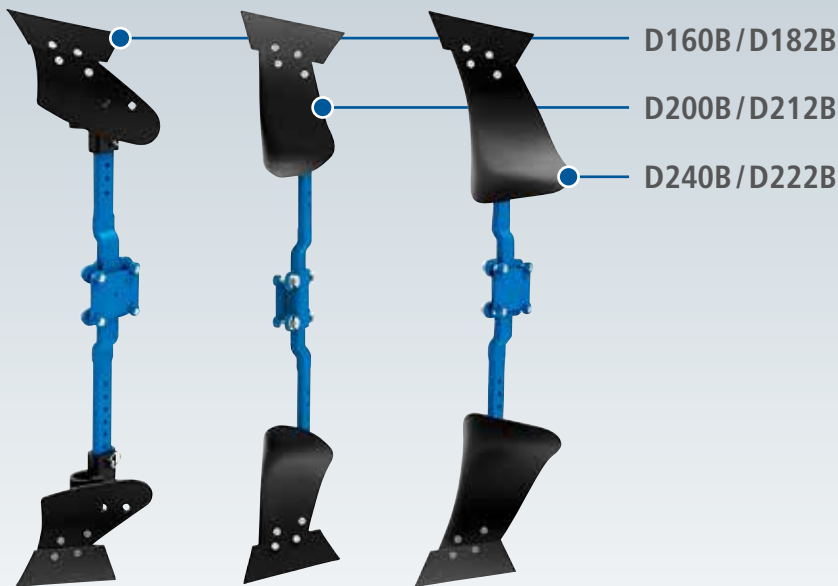

### Skimmers for Corn or Manure

Skimmers are recommended in light to medium residue levels and when the ploughing depth has to be changed often. RABE offers a manure skimmer and a corn skimmer in two sizes, depending on how many straw has to be incorporated into the soil.

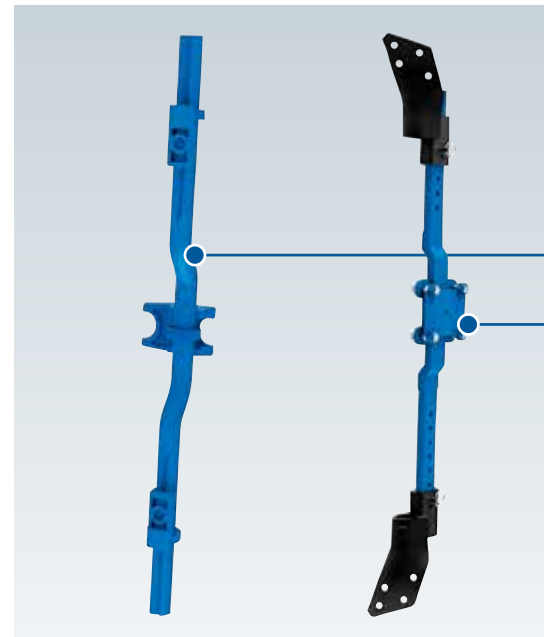

### Skimmer legs

RABE skimmers are mounted either on flat VARI-FIX or on a round leg. VARI-FIX skimmers allow a simple vertical adjustment and avoid making serious mistakes. For stony grounds the VARI-FIX skimmers can be ordered optionally equipped

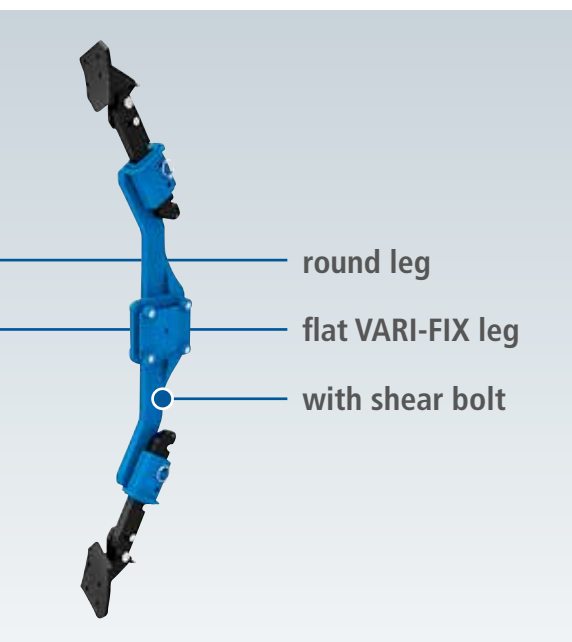

### Trashboards

with shear bolt. With skimmers mounted on round legs the skimmer angle is adjustable and the residue flow can be influenced for a clean field whatever residue you deal with.

Trashboards are recommended in high residue fields and provide more interbody clearance for a proper residue flow without the risk of plugging. They always require a constant ploughing depth which should be not too flat.

# MATCHING YOUR INDIVIDUALS CONDITIONS EVEN BETTER.

## Cutting the Edge.

Depending on your conditions you may need a little help from our accessoires to achieve the best results with your RABE plough.

### Disk Coultter

The disk coultter with wavy or notched blade is recommended for medium size residue levels. It can be adjusted for shallow and properly cuts of the furrow wall. Soil does not stick to the blade when working in clayey conditions.



### Knife Coultter

The knife coultter is the perfect choice for medium size residues. It cuts the top layer of soil along the furrow and separates the main bodies from each other in heavy soils.

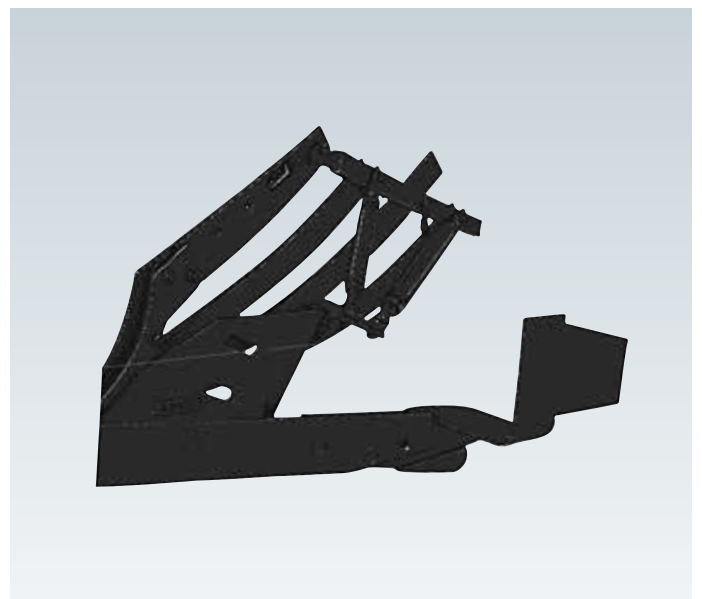

### Furrow Widener

A furrow widener can be attached to the last body to smoothen the sharp edge of the furrow and allow wider tyres to fit. It helps to reduce compaction and prevents the tyre from damages.

## Subsoiler

Subsoiler remove any hard or plough pan to avoid soil wetness in the ploughing horizon and support an excellent root development for improved plant growth and higher yields.



## Clod Cracker

In heavier conditions they ensure that bigger clods are sliced properly to leave a finer field finish.

## Traction Step

The traction step is available for certain SUPER ALBATROS plough models. It adds another pair of smaller mouldboards at the end of the plough. This smaller mouldboard ploughs about the half depth and creates a wide flat furrow edge to allow very wide tyres (up to 900!) to fit into it.

# SUPERIOR SOIL SOLIDIFICATION.

## Combining Applications – Controlling Cost.

Adding a packer to the ploughing pass or separating it from ploughing and combining it with the seeding pass is indeed a question of individual farm philosophy. However with RABE you are on the safe side. RABE offers both. Single ring packer with a 900 mm ring diameter are available in different sizes from 1.50 m up to 3.70 m working width. RABE double ring packer go up to 4.35 m working width and can be ordered with either 700 or 900 mm ring diameter. All ring packers are made from ductile graphite iron to withstand the toughest conditions.

- + Single ring packer are recommended for light to medium soils
- + Double ring packer are the right choice for soils with a high loam and clay content
- + The ring shoulders and the overall profile of the ring as well as the distance between the rings has been optimized to perfectly slice through tough soils
- + Scraper chains avoid any plugging
- + Optional Crosskill roller for additional clod breaking and packing

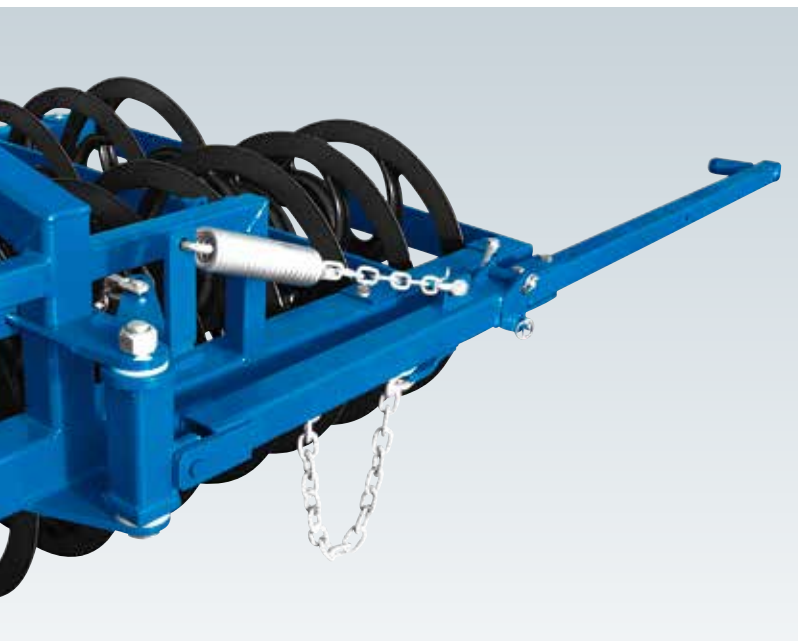

### Suspended Catching Arm

The catching arm of the packer is suspended with a chain and a coil spring to keep the catching arm off the ground and ensure a proper catching of the packer. The catching arm can be detached and parked on the packer For safe road transport.



### Frame Extension

RABE packer grow with your plough and operation. Certain models can be extended by one or two rings on each side to exactly match the working width of the plough with a decent overlap.



### Endwise Transport

Packer, wider than three meter working width, need to be transported endwise to meet the individual road restrictions in Europe. Therefore RABE packer can be equipped an integrated transport carriage that can stay on the packer when ploughing in the field and be easily converted for road transport.



### Three-Point Linkage

For packers, 3 m working width and smaller, an integrated 3-point linkage system for road transport is available, too. It allows to connect the packer to the tractor to get from field to field, quickly.

More than ploughs.

## RABE PORTFOLIO.

### RABE – Preeminent expertise in tillage, seeding and fertilizing.

RABE is more than ploughs – RABE is your strong partner when it comes to tillage and seedbed preparation to offer you complete, tailor made solutions making your job easier, more productive and more reliable in all of your key applications throughout the year. It's our commitment to support your business to ensure maximum farm profitability at the lowest cost of operation. Our today's portfolio seamlessly integrates into your farming operation when it comes to conventional tillage applications.





## RABE SERVICE.

### Partnership is part of our DNA.

A successful partnership is always based upon trust and understanding. At RABE trust is evident in the quality and reliability of our products, the efficiency of our user friendly machine operation and the meticulous support provided by the RABE service team and our RABE dealers in the field. We also understand exactly what you need to achieve and maintain the success of your operation by delivering critical parts in time through our parts distribution center in Bad Essen.



The original for top performance.

# RABE GENUINE PARTS – A GOOD INVESTION.

## Durable. Reliable. Proven Quality.

In order to maintain the reliability of your machine, please do not save on RABE genuine parts, but save with RABE original parts: We manufacture our parts from special steel especially produced for RABE with the highest value in hardness and toughness. As a result, our parts have considerably longer service life. This will save money in the long run and also a lot of working time because you have to change the wear parts less frequently.

RABE provides at least for 10 years wear and spare parts for all equipment – usually even longer. Feel free to ask also for older devices – we are happy to help.

### + Impressive work rates

through maximum hardness and toughness.

### + Better quality of work

through longlife original parts.

### + Better price-performance relationship

with durable original parts that pay.

### + Time and cost savings

because of less frequent change of wearparts.

### + Longer lifetime

thanks to special coating and finishing processes.

### + Less tractive power needed

through low drag resistance.

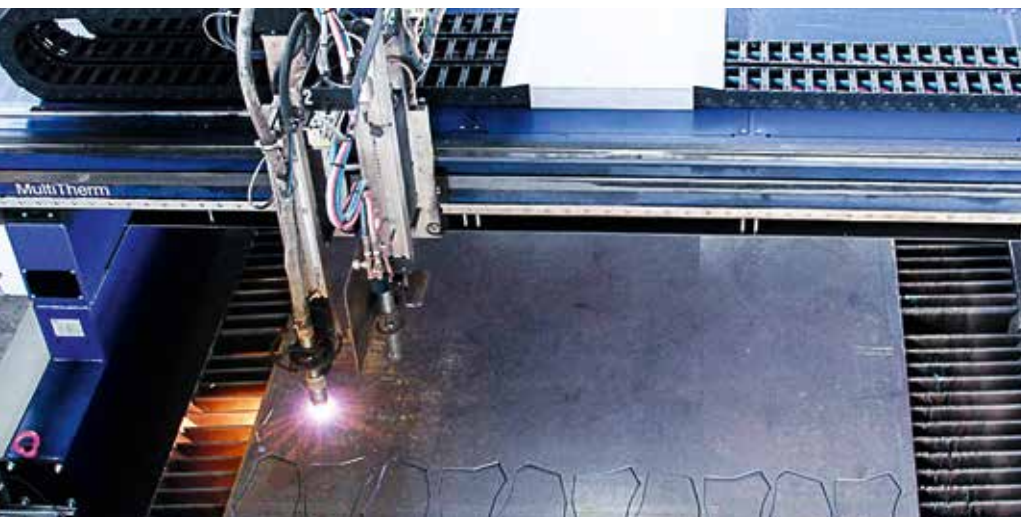



## Your would like to order RABE genuine parts?

1. Mail, fax or call.
2. Specify [customer and order number](#) or [machine number](#).
3. Your original part is already on your way to you.

Tel.: +49 (0) 5472 771 -0  
Fax: +49 (0) 5472 771 -100  
[www.rabe-agrartechnik.de](http://www.rabe-agrartechnik.de)



Your RABE dealership for outstanding on-site service:

This literature has been compiled for worldwide circulation. While general information, pictures and descriptions are provided, some illustrations and text may include product options and accessories not available in all countries. Please contact RABE or your local dealer directly. RABE reserves the right to change specifications and design of products described in this literature without notice.



RABE Agrartechnik Vertriebsgesellschaft mbH | Am Rabewerk 1 | 49152 Bad Essen | Germany  
Tel. +49(0)5472-771-0 | Fax. +49(0)5472-771-100 | info@rabe-agrartechnik.de | www.rabe-agrartechnik.de